

***Honeyville***

**Distributors**



**Hot Dip Galvanized For Long Life and Low Maintenance**

Flat Back or Full Round Models, 45° or 60° Flow







Distributor service door platform mounts on the door frame and is an option for all distributors.



Swing spout bottom is Urethane lined for extended wear, side liners are optional.



Positive locking index plate located under the distributor for protection from dust and weather.



Swing spout rotates on a solid shaft with a flanged block bearing.



No tools required to open door for cleaning and maintenance. All internal parts can be disassembled and removed through the opening.



Internal swing spout with flanged connections for ease of replacement.



Adjustable brush on the swing spout for reducing dust buildup.



Spring tensioned latch mechanism.





**Electronic Positioning Control (“EPC”)**  
Includes pre-programmable PLC, variable frequency drive, HMI touch screen LED display with standard multi key functionality and EZ-Grid mode for single touch button operations, main power on/off selector switch and all components housed in a NEMA 4X/6P fiberglass enclosure.



Weather tight enclosure housing a shaft mounted gear reduction direct drive package with AC motor. The positioning of the internal spout is controlled by a micro processor with no mechanical limit switches required. All this is easily accessible through a large service door.



Typical installation of an EPC 8 hole distributor, shown on a model 43-24 elevator.

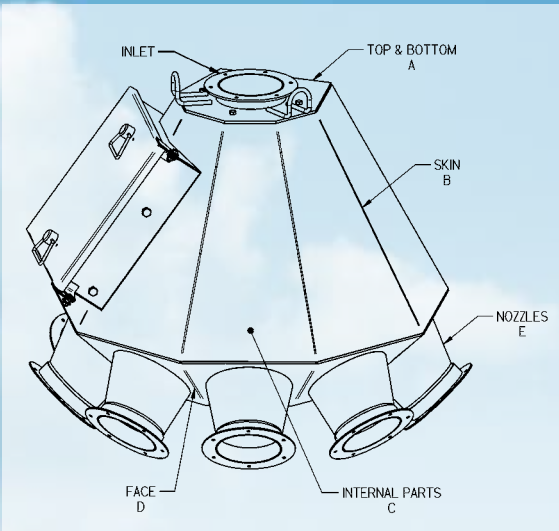

| Inlet & Nozzle Dia. | Distributor Material Specifications |       |        |        |       |        |
|---------------------|-------------------------------------|-------|--------|--------|-------|--------|
|                     | Group #                             | A     | B      | C      | D     | E      |
| 6", 8", 10"         | 1                                   | 1/4"  | 12 Ga. | 10 Ga. | 7 Ga. | 10 Ga. |
| 12", 14"            | 2                                   | 5/16" | 10 Ga. | 7 Ga.  | 1/4"  | 7 Ga.  |
| 16", 18", 20"       | 3                                   | 3/8"  | 10 Ga. | 1/4"   | 1/4"  | 1/4"   |

| Distributor EPC Information |                       |        |                 |                      |
|-----------------------------|-----------------------|--------|-----------------|----------------------|
| Group #                     | Primary input voltage | Motor  | Drive enclosure | Controller enclosure |
| 1                           | 120 / 60 / 1          | 1/8 hp | 18" x 18" x 29" | 18" x 9" x 19"       |
| 2                           | 220/440 / 60 / 3      | 1/4 hp | 24" x 24" x 47" | 18" x 9" x 19"       |
| 3                           | 220/440 / 60 / 3      | 1/2 hp | 24" x 24" x 47" | 18" x 9" x 19"       |

## Features

- Control options: Pipe Control (standard), Cable Control, or Electronic Positioning Control ("EPC") for remote operations
- Optional Stainless Steel in place of hot dip galvanized construction
- Optional urethane lining of the swing spout and outlet nozzles
- Enlarged transition throat for higher capacity at the critical turning point in the grain flow with standard urethane lining
- Hot dip galvanizing after the fabrication process provides rust protection on the internal and external surfaces
- The swing spout assembly rotates on 4 guide bearings at the top and a flange block bearing at the bottom for smooth movement

### Pipe Control

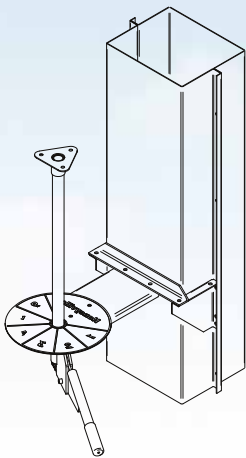

### Cable Control

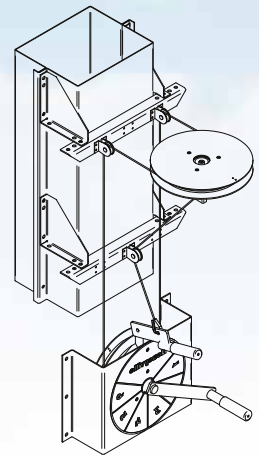

Fully Enclosed - Dust and Weather Tight

Manufactured by



4200S 900W • Topeka, IN 46571  
 Phone (800) 593-8377 • Fax (260) 593-2486  
[www.honeyvillemetal.com](http://www.honeyvillemetal.com)