

***Honeyville***

**Incline  
Drag Conveyors**

**GENTL-FLOW**

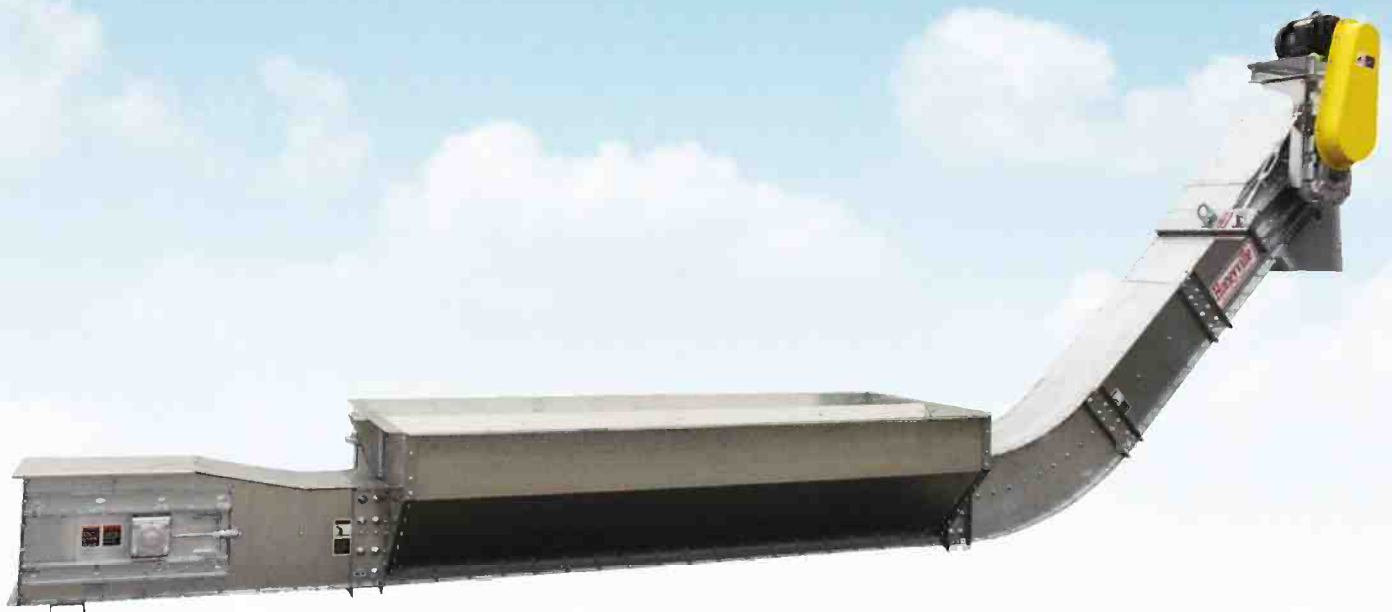

**Galvanized For Long Life **and** Low Maintenance**

**3 Sizes – Capacities up to 11,000 BPH**





# GENTL-FLOW INCLINE DRAG CONVEYORS

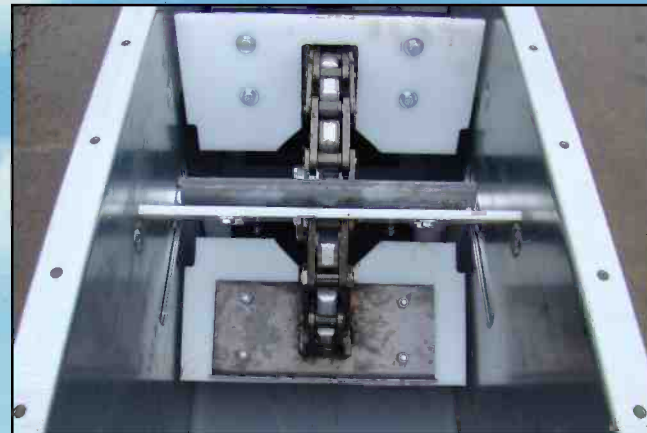

Each UHMW paddle bolts onto a large, formed steel backer plate that is welded onto the chain.

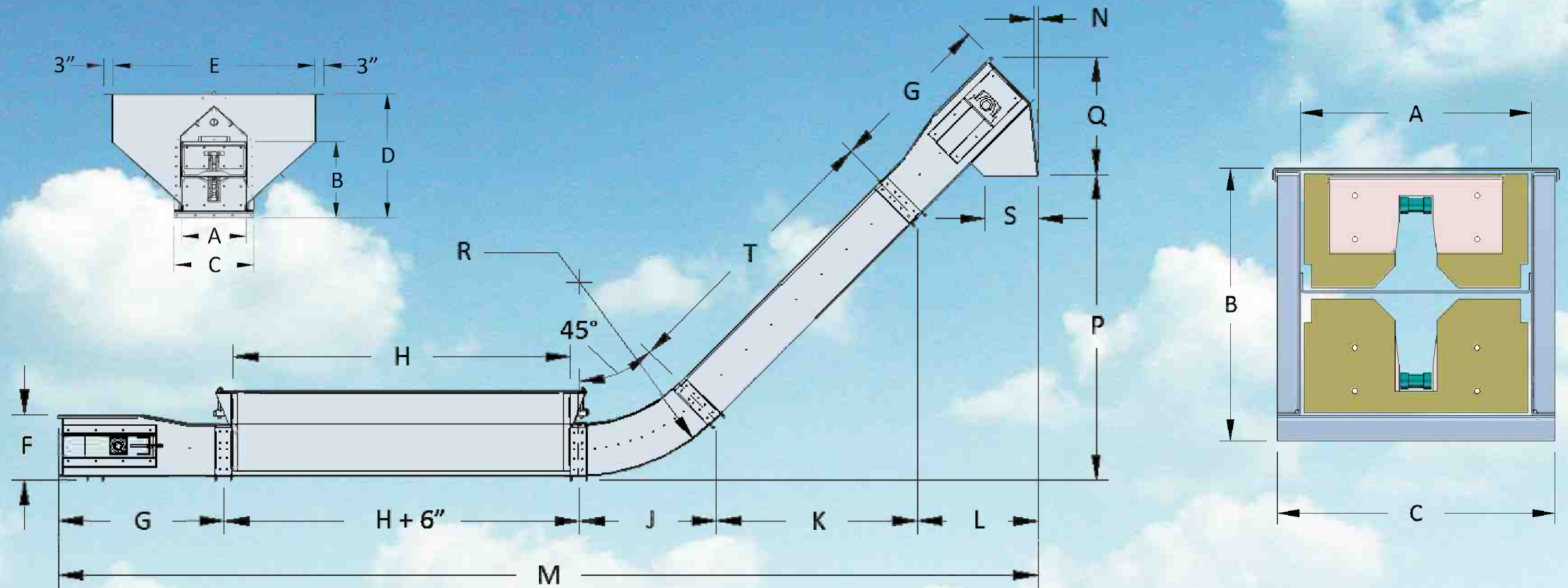

Incline Drag Conveyor Specifications																				Galvanized Material Specifications				
Model	Capacity Range	Chain	A	B	C	D	E	F	G	H	J	K	L	M	N	P	Q	R	S	T	Head & Tail	Bottom	Sides	Cover
HD-F13IC	2,500 - 4,500 BPH	81XH	13	18-3/4	16-1/4	30	48	22	55-7/8	114	46-1/8	59-3/8	40-3/4	322-1/8	1-1/2	94-1/2	39-5/8	65	18	84	10 Ga.	10 Ga.	12 Ga.	14 Ga.
HD-F16IC	5,000 - 7,000 BPH	81XH	16	18-3/4	19-1/4	30	48	22	55-7/8	114	46-1/8	67-7/8	40-3/4	330-5/8	1-1/2	103	39-5/8	65	18	96	10 Ga.	10 Ga.	12 Ga.	14 Ga.
HD-F22IC	7,500 - 11,000 BPH	81XH	22	21-3/4	25-1/4	36	48	25-1/2	57-1/4	114	46-1/8	76-3/8	41-7/8	341-3/4	1-1/2	112-5/8	41-7/8	65	18	108	10 Ga.	10 Ga.	12 Ga.	14 Ga.

\*All dimensions shown above are in inches



Screw take-up assembly on tail section and outboard mounted flange bearings with shaft seals



Smooth, self-cleaning slopes inside pit hopper. Quick and easy flow control adjustment on each end of the hopper.

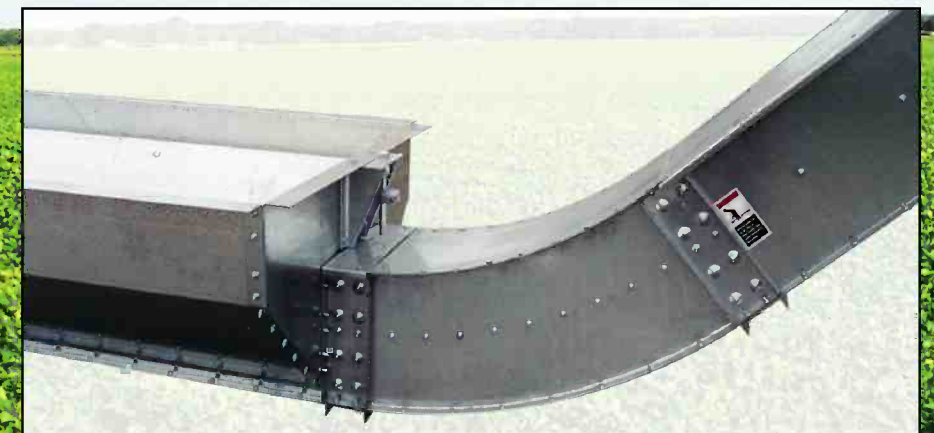

Long radius, high flow bend sections with optional bottom AR steel liners.

## Features

- All G-90 galvanized, bolted construction, pre-assembled head, bend, tail and individual trough sections
- Conveyor sections throughout have formed top and bottom lips with formed bolt-on channels at adjoining points on the sides and bottom
- Bolt-in AR steel liner options for the bottom for extended conveyor life
- Drive over pit hopper, 4' or 5' wide, available in varying lengths
- Pit grates: 1/2" x 3" flat bars on 4' wide hoppers, 1/2" x 4" flat bars on 5' wide hoppers
- Heavy duty 81XH steel chain with welded steel attachments
- Bolt-on 3/8" thick UHMW paddles
- Class II Dodge torque-arm type gear reducers installed with fixed pitch v-belt drives
- Long radius, high flow incline bend sections available in 15°, 22.5°, 30°, 37.5° and 45°



Drive-over pit hopper with bar grate provided in 12" wide lift-out sections for easy access



Typical application: Incline Drag Conveyor in a pit, feeding an elevator boot above grade

## Gently Moving Nature's Grains

Manufactured by



4200S 900W • Topeka, IN 46571  
Phone (800) 593-8377 • Fax (260) 593-2486  
[www.honeyvillemetal.com](http://www.honeyvillemetal.com)