





# Specifications

General	
Model No.	EPC-GR3
Serial No.	
Software Version	3.3
Dealer Name	
Order No.	
Distributor Model No.	
Distributor Serial No.	

AC Drive Parameters			
		Factory Setting	User Setting
Motor Parameters			
P0.00	Motor Nameplate Voltage		
P0.01	Motor Nameplate Amps		
P0.03	Motor Base RPM		
Ramp Parameters			
P1.01	Acceleration Time 1		
P1.02	Deceleration Time 1		
Voltz/Hertz Parameters			
P2.00	Volts/Hertz Settings		
P2.01	Slip Compression		
P2.10	Control Mode		
Digital Parameters			
P3.00	Source of Operation Command		
P3.02	*Multi-Function Input DI3		
P3.04	*Multi-Function Input DI5		
Presets Parameters			
P5.01	Multi-Speed 1		
P5.02	Multi-Speed 2		
P5.03	Multi-Speed 3		

All Parameters not listed above are at default setting.

\*P3.04 must be set before P3.02.

Power Requirements	
<input type="checkbox"/>	220-240 VAC 3Phase 60 Hz
<input checked="" type="checkbox"/>	440-480 VAC 3Phase 60 Hz

PLC Settings		
		User Setting
Setup		
Setup Password	555	
Alignment Factor		
Outlets		
Spacing		
Checkpoint		
Precision		
Resolution		
Ratio		
Medium Range		
Slow Range		
Green Range		
Safety Timer		
Remote Type		
Calibration Type		
Encoder Directon		
Use Nicknames		

	Factory Setting	User Setting
Skip Outlets		
Skip Outlet 1	0	
Skip Outlet 2	0	
Skip Outlet 3	0	
Skip Outlet 4	0	
Skip Outlet 5	0	
Skip Outlet 6	0	
Skip Outlet 7	0	
Skip Outlet 8	0	
Skip Outlet 9	0	
Skip Outlet 10	0	
Skip Outlet 11	0	
Skip Outlet 12	0	
Skip Outlet 13	0	
Skip Outlet 14	0	
Skip Outlet 15	0	
Skip Outlet 16	0	
Skip Outlet 17	0	
Skip Outlet 18	0	
Skip Outlet 19	0	
Skip Outlet 20	0	
Skip Outlet 21	0	
Skip Outlet 22	0	
Skip Outlet 23	0	
Skip Outlet 24	0	
Nicknames		
Nickname 1		
Nickname 2		
Nickname 3		
Nickname 4		
Nickname 5		
Nickname 6		
Nickname 7		
Nickname 8		
Nickname 9		
Nickname 10		
Nickname 11		
Nickname 12		
Nickname 13		
Nickname 14		
Nickname 15		
Nickname 16		
Nickname 17		
Nickname 18		
Nickname 19		
Nickname 20		
Nickname 21		
Nickname 22		
Nickname 23		
Nickname 24		



PARTS LIST

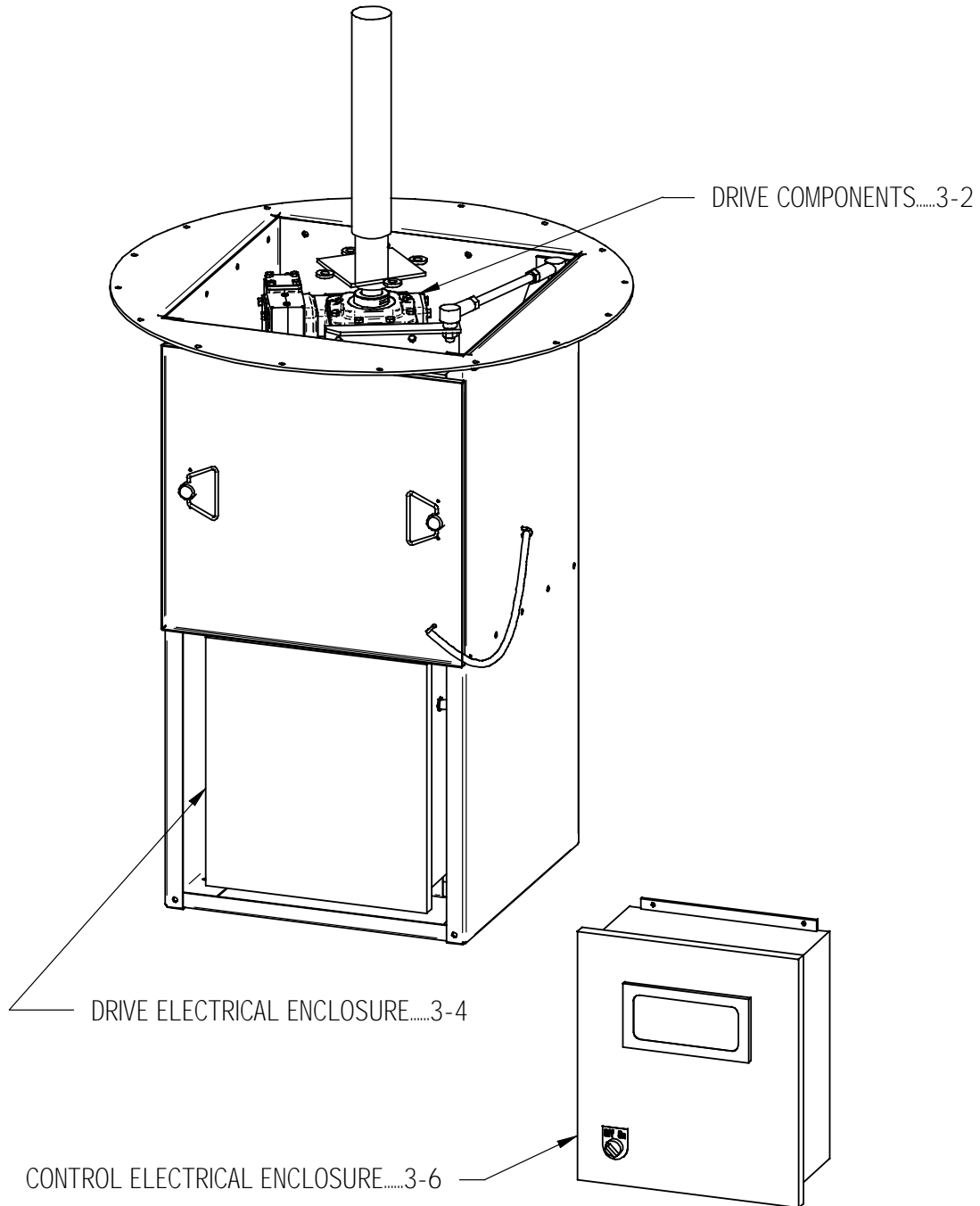

**DRIVE COMPONENTS**

Item	Part	Qty	Description
1		1	Ø 2 15/16 TGP Shaft
2		1	Drive Cabinet
3		1	Cabinet Door
4		1	Torque Arm Mount
5	DSHW1101	2	5/8"-18 Female Rod End
6		1	5/8"-18 Threaded Rod x 10¾"
7		4	5/8"-18 Hex Nut
8	PTGR1221E	1	Winsmith 935MDSND 500:1 Gear Reducer
9	PTEM0997	1	Black Max Y534 Motor 1/2 HP
10	DSHW1034A	1	Dynapar HS35R2000H37D Encoder
11		2	3/16" U-Bolt
12		1	3/16" Chain x 19"
13	HWF0501	4	5/8" Extra Thick Flat Washer
14		1	Shaft Seal
15	HWSC1024	1	1½" Shaft Collar

# DRIVE COMPONENTS

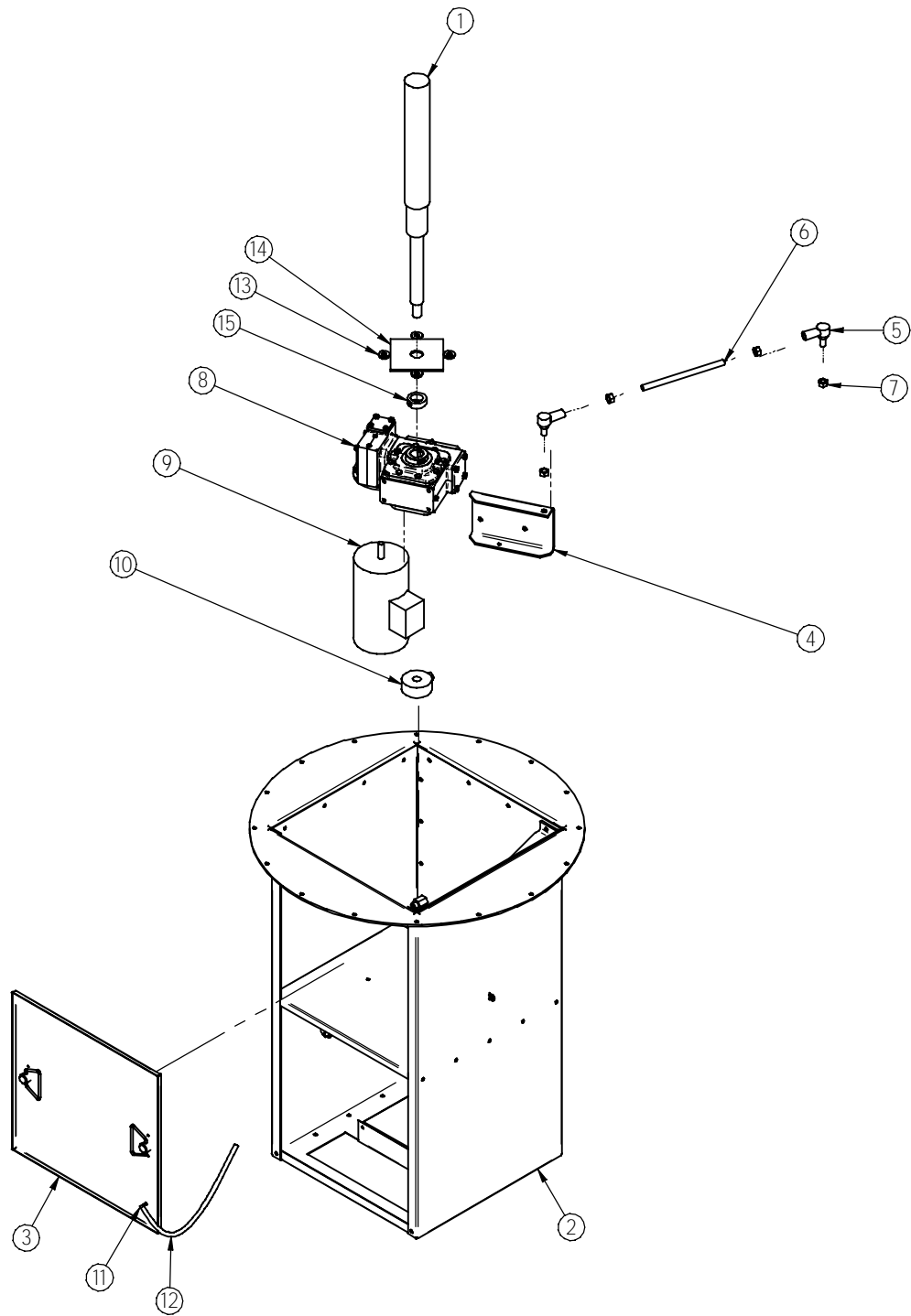

## DRIVE ELECTRICAL ENCLOSURE

Item	Part	Qty	Description
1	DSHW1040	1	Fiberglass Enclosure
2	DSHW1114	1	RF022B43AA EMI Filter
3	DSHW1115	1	DURApulse GS3-41P0 AC Drive
4	DSHW1111	1	GS-41P0-LR 460V AC Line Reactor
5	DSHW1112	2	RF220X00A RF Filter
6	DSHW1039	1	Enclosure Heater; 60 Watt; 60/40 T-Stat
7	DSHW1008	2	Terminal Block Ground
8	DSHW1011	17	Terminal Block Blue
9	DSHW1010	1	Terminal Block Gray
10	DSHW1002	1	2 Pole Jumper Bar
11	DSHW1006	2	End Bracket

# DRIVE ELECTRICAL ENCLOSURE

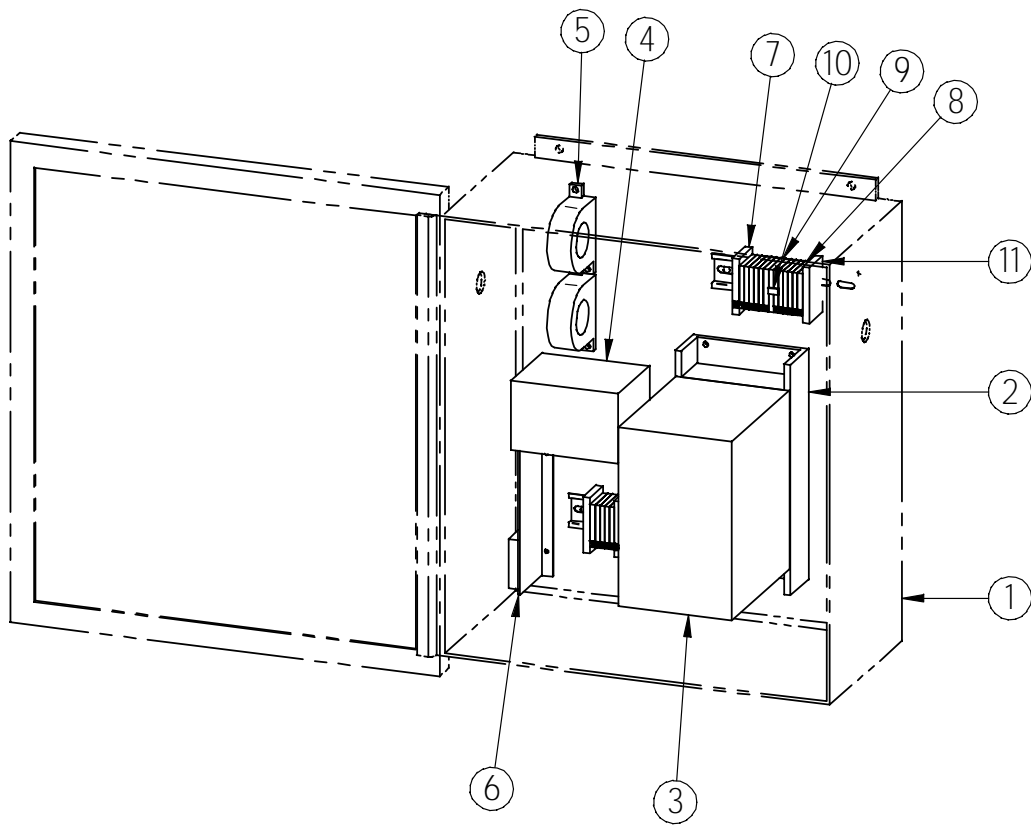

---

**CONTROL ELECTRICAL ENCLOSURE**

Item	Part	Qty	Description
1	DSHW1040	1	Fiberglass Enclosure
2	DSHW1110	1	GS-41P0-FKIT Fuse Kit for GS2/GS3-41P0
3	DSEC1002	1	240/480V to 120V Transformer
4	DSHW1116	1	LC1K0910F7 IEC Mini Contactor
5	DSHW1019	1	PS24-075D 24VDC Power Supply
6	DSHW1018	1	D0-06DD1-D Direct Logic PLC
7	DSHW1006	3	End Bracket
8	DSHW1010	11	Terminal Block Gray
9	DSHW1011	20	Terminal Block Blue
10	DSHW1008	3	Terminal Block Ground
11	DSHW1002	1	2 Pole Jumper Bar
12	DSHW1003	3	3 Pole Jumper Bar
13	DSHW1004	1	4 Pole Jumper Bar
14	DSHW1082	1	30MM Selector Switch
15	DSHW1081	1	30MM Contact Block
16	DSHW1080	1	30MM Nameplate Off/On
17	DSHW1022	1	EZ-220P EZText Operator Panel
18	DSHW1026	1	EZ-BRK-2 EZText Mounting Clips
19*	DSHW1014	1	EZ-2CBL EZText Cable
opt 20	DSHW1039	1	Enclosure Heater; 60 Watt; 60/40 T-Stat

# CONTROL ELECTRICAL ENCLOSURE

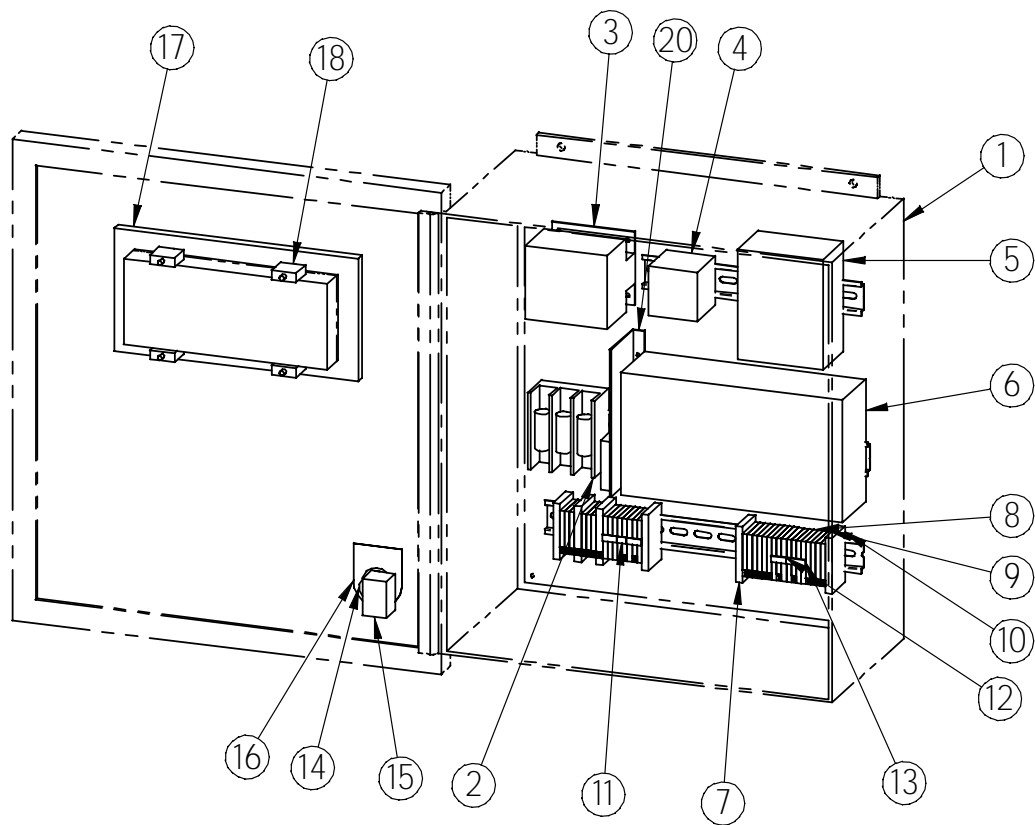

*This page intentionally left blank.*

# DRIVE ELECTRICAL ENCLOSURE

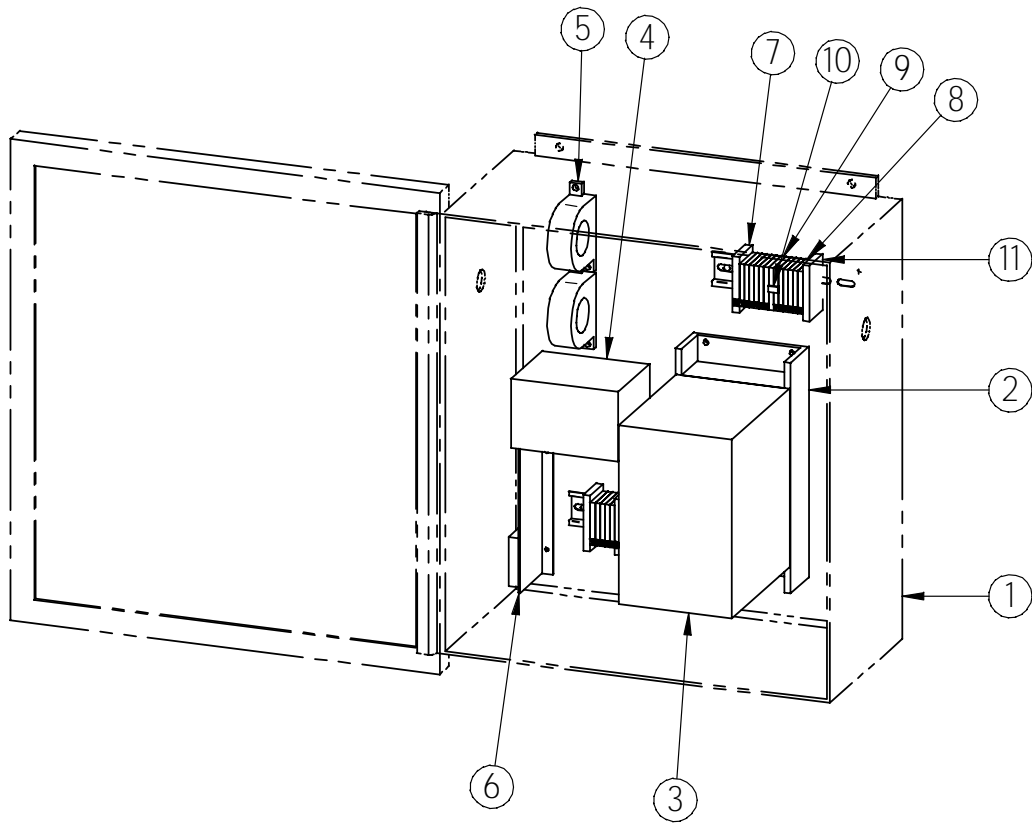

## CONTROL ELECTRICAL ENCLOSURE

Item	Part	Qty	Description
1	DSHW1040	1	Fiberglass Enclosure
2	DSHW1110	1	GS-41P0-FKIT Fuse Kit for GS2/GS3-41P0
3	DSEC1002	1	240/480V to 120V Transformer
4	DSHW1116	1	LC1K0910F7 IEC Mini Contactor
5	DSHW1019	1	PS24-075D 24VDC Power Supply
6	DSHW1018	1	D0-06DD1-D Direct Logic PLC
7	DSHW1006	3	End Bracket
8	DSHW1010	11	Terminal Block Gray
9	DSHW1011	20	Terminal Block Blue
10	DSHW1008	3	Terminal Block Ground
11	DSHW1002	1	2 Pole Jumper Bar
12	DSHW1003	3	3 Pole Jumper Bar
13	DSHW1004	1	4 Pole Jumper Bar
14	DSHW1082	1	30MM Selector Switch
15	DSHW1081	1	30MM Contact Block
16	DSHW1080	1	30MM Nameplate Off/On
17	DSHW1022	1	EZ-220P EZText Operator Panel
18	DSHW1026	1	EZ-BRK-2 EZText Mounting Clips
19*	DSHW1014	1	EZ-2CBL EZText Cable
opt 20	DSHW1039	1	Enclosure Heater; 60 Watt; 60/40 T-Stat

# CONTROL ELECTRICAL ENCLOSURE

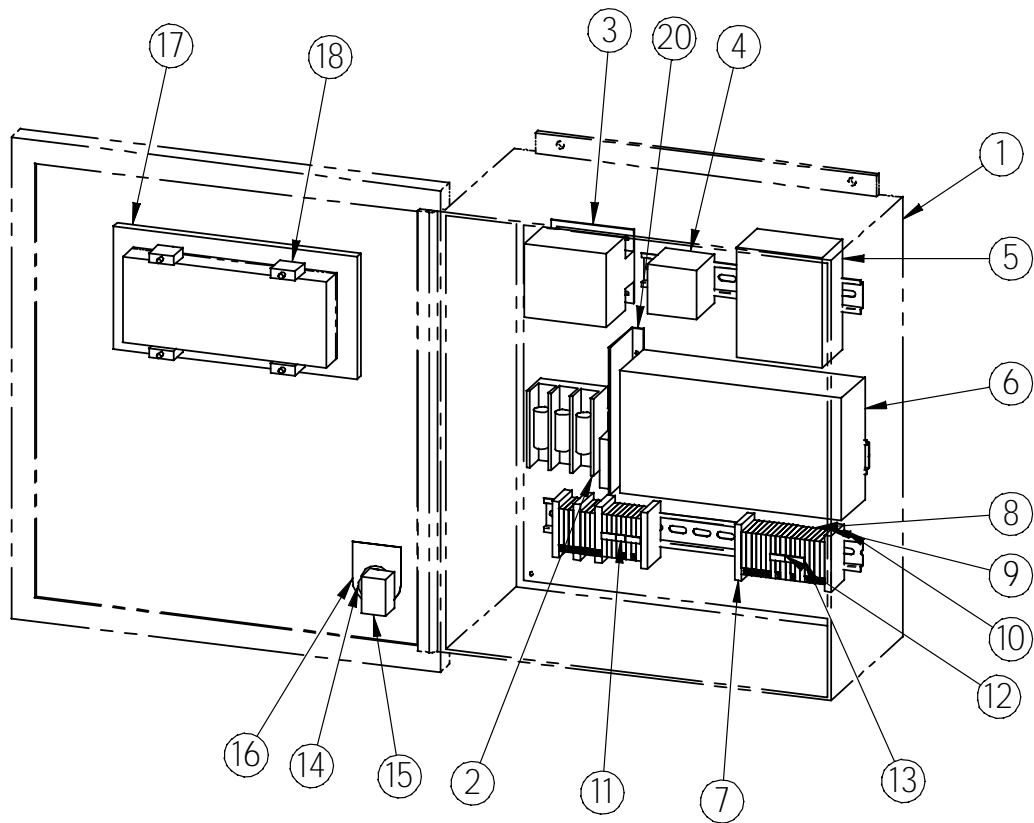

*This page intentionally left blank.*

---



---

## INSTALLATION

### ***Transportation***

Do not put excessive stress on the drive enclosure. If the electric control is attached to a distributor, transport the distributor on its back

### ***Environment***

Mount the control enclosure in a clean, dry, indoor environment. Please observe these operating temperatures:

Operating Temperatures		
	Minimum	Maximum
Control Enclosure	40° F	120° F
Drive Enclosure	-40° F	185° F

If the control enclosure needs to be mounted in a location where the temperature could drop below 40° F, there is an optional enclosure heater available (HMI item # DSHW1039).

### ***Disconnect Switch***

It is the responsibility of the end user to install the appropriate power disconnect between the incoming power supply and the controller.

### ***Wiring***

#### **Connect the AC Lines**

- ∅ 6 conductors of 14 AWG wire are required.
- ∅ Always take the shortest distance between the control and drive enclosures.
- ∅ Run the AC wire in its own conduit. If possible, keep 12” away from the DC lines.
- ∅ Do not allow DC lines to cross AC lines
- ∅ Connect wires to the blue terminals labeled T1, T2, T3, G, 51 and 52 in the control enclosure; connect the other end to the corresponding blue terminals in the drive enclosure.
- ∅ Keep AC wiring to the lower left side of the control enclosure, and to the left side of the drive enclosure.

#### **Connect the DC Lines**

- ∅ 12 conductors of 18 AWG wire are required.
- ∅ For best results, use Belden 9556 or equivalent 18 AWG 6 twisted pair shielded control cable.
- ∅ Always take the shortest distance between the control and drive enclosures.
- ∅ Run the DC cable in its own conduit. If possible, keep 12” away from AC lines.
- ∅ Do not allow DC lines to cross AC lines

- ⊄ Connect wires to the blue terminals labeled 1 to 12 in the control enclosure; connect the other end to the corresponding blue terminals in the drive enclosure.
- ⊄ Use a twisted pair for connections 1 & 2, 3 & 4, 5 & 6, 7 & 8, 9 & 10, and 11 & 12.
- ⊄ Connect the shield to ground in the control enclosure only. Do not connect shield to ground in the drive enclosure.
- ⊄ Keep DC wiring to the lower right side of the control enclosure, and to the right side of the drive enclosure.

### ***Test the Rotation***

When the wiring is complete, you must test the rotation of the motor. Press the “Manual” button on the Operator Panel to enter the Manual Mode. While pressing the “Up” arrow on the keypad, verify the following:

1. The number showing on the display should be increasing.
2. The spout should be rotating counter-clockwise when viewed from the top.

If the spout is rotating in the opposite direction, switch the T1 and T3 wires in the control enclosure and repeat steps 1 and 2.

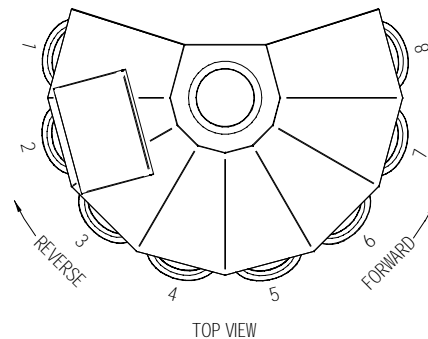

### ***Adjust the Reference Point on the Encoder***

**The reference point on the encoder has been preset at the factory. Under normal circumstances you should not need to make any changes to the reference point on the encoder.**

If the encoder has been removed, you will need to follow this procedure for setting the reference point:

1. Use manual mode to turn the spout to outlet 1, which is the outlet to the left of the door.
2. Continue to use manual mode to align then left side of the spout with the left side of the top of the outlet.
3. In the drive enclosure, remove the cover from the bottom of the encoder.
4. Loosen the collar inside the encoder.
5. Rotate the collar to align the indent on the collar with the center of the cord.
6. Tighten the collar.
7. With the power on in the control enclosure, check the X2 light on the PLC. If it is lit, continue to step 10.
8. Loosen the bolt on the anchor tab on the encoder, and rotate the encoder slightly until the X2 light on the PLC is lit. Tighten the bolt.
9. Repeat steps 7 and 8 until the X2 light on the PLC is lit.
10. Replace the cover on the bottom of the encoder.
11. You will need to calibrate, and then adjust the alignment factor. See “Alignment Factor” in the “Setup Function” section of the “Operation” chapter.

## OPERATION

### *Warning*

Do not allow material to flow through the distributor unless the Electronic Positioning Controller is powered on and in Run or Remote mode, and the Ready light is illuminated green.

### *Direction of Travel*

In this documentation, forward means the spout is moving up to a higher outlet number, toward the last outlet, or counterclockwise when looking at the Distributor from above.

Reverse means the spout is moving down to a lower outlet number, toward the first outlet, or clockwise when looking at the Distributor from above.

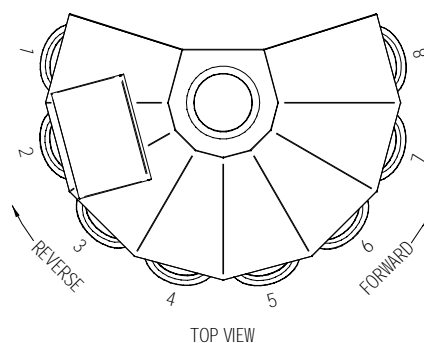

### *Status Lights*

READY		MOVING		ERROR
-------	--	--------	--	-------

Light	Color	Description
Ready	Green	Spout is in position. Distributor is ready to be used.
	Red	Spout is not in position. Do not use distributor.
Moving	Yellow	Spout is in motion.
Error	Yellow	Action required. Follow on-screen instructions.
	Red	See "Troubleshooting" chapter.

## *Functions*

MANUAL		SETUP		CALIB		RUN		REMOTE
--------	--	-------	--	-------	--	-----	--	--------

There are five function buttons on the operator panel. Press a function button to enter a mode of operation.

If an error is generated, you will need to restart the function that you were in. Example: If you are in the Run Function and enter the number "0" as the outlet to move to, an "Invalid Entry" message will appear in the display. Press the "Run" button to return to the Run Function.

### *Manual Function*

- Enter the Manual Function by pressing the "Manual" button on the Operator Panel.
- The Manual Function is primarily for diagnostic and maintenance purposes.
- The number displayed is the distance from the zero reference point.
- Use caution when using the Manual Function; it is possible to run the spout into the back wall of a Flatback Distributor.

#### Process

1. Press the Up arrow on the Operator Panel to move the spout forward.
2. Press the Down arrow to move the spout in reverse.

### Setup Function

- Enter the Setup Function by pressing the "Setup" button on the Operator Panel, then pressing the "Esc" button.

Honeyville EPC
Version 3.3
+Settings
+Skip Outlets
+Nicknames
+Status
Save Settings?

-Settings
Alignment Factor?
Outlets?
Spacing?
Checkpoint?
Precision?
Resolution?
Ratio?
Medium Range?
Slow Range?
Green Range?
Safety Timer?
Remote Type?
Calibration Type?
Encoder Direction?
Use Nicknames?
-Skip Outlets
Skip Outlet 1?
Skip Outlet 2?
...
Skip Outlet 24?
-Nicknames
Nickname 1?
Nickname 2?
...
Nickname 24?
-Status
Encoder:
Current Pos:
Target Pos:
Calib Low:
Calib High:
Green Low:
Green High:

- The Setup Function needs to be run at least once before you can start the Calibrate or Run Functions.
- Changes to settings are effective immediately; however, they will not be retained if the power is shut off unless you change the value of "Save Settings" to 1.
- If your Electronic Control was purchased with a new Honeyville Distributor, the settings have been pre-set at the factory. You should go through the Setup Function to verify the settings.
- The Setup menu is arranged in a hierarchy with folders and messages. A plus (+) is displayed in front of a folder's name if it is closed. Press the "Enter" button to open a folder. If a folder is open, a minus (-) is placed in front of the name. Any messages within that folder will be displayed below it. You may use the UP/DOWN arrow buttons to scroll down to the next message in that folder. At the end of the messages for that folder, you can press the "Esc" button to move to the previous level.
- The settings can be viewed without a password. If you need to change a setting, you are required to enter a password.
- See enclosed "Specifications Sheet" for the password and the settings described below.

### Process

#### 1. Alignment Factor

- These adjustments ensure that the spout will lock into position when centered on the outlet.
- You only need to set the alignment adjustments for one outlet. Assuming that all of your other settings are correct, if the alignment is set correctly for one outlet, all other outlets will also be correct.
- If the spout is stopping to the right of center, use a smaller number.
- If the spout is stopping to the left of center, use a larger number.
- These adjustment numbers are obtained through a trial and error process in which the spout is moved to an outlet, and then visually inspected for centeredness.
- During the trial and error process described above, if you have previously completed Setup and Calibration, you can press "Run" and not be forced to calibrate. You can move the outlet to a different outlet, (then back again if you wish), then press "Esc" to return to setup and enter another number and repeat the process. When you are satisfied with the position of the spout, be sure to "Save Settings" as described below.

#### 2. Outlets

- This number is equal to the number of outlets on your Distributor.

3. Spacing
  - This number is distance between outlets on the Distributor.
  - The number based on the precision setting.
  - To calculate this number, take the degrees between outlets and multiply by the precision setting, and then divide the result by 360.
4. Checkpoint
  - This setting is not used on model EPC-GR3.
5. Precision
  - This is the number of counts for one complete revolution of the spout in the distributor.
  - This setting is 1800 on model EPC-GR3.
6. Resolution
  - This is the resolution of the encoder.
  - This setting is 1800 on model EPC-GR3.
7. Ratio
  - This is the ratio of the gearbox if the encoder is attached to the motor. If the encoder is attached directly to the distributor shaft, this setting will be 1.
  - This setting is 1 on model EPC-GR3.
8. Medium Range
  - As the spout approaches the target position, the motor begins to slow down. This number determines the point at which it slows from high speed to medium speed.
  - Increase this number to have the motor slow down earlier; decrease this number to have the motor slow down later.
9. Slow Range
  - As the spout approaches the target position, the motor begins to slow down. This number determines the point at which it slows from medium speed to slow speed.
  - Increase this number to have the motor slow down earlier; decrease this number to have the motor slow down later.
10. Green Range
  - This number determines the distance the spout is allowed to move off of its target before the "Ready" light changes from green to yellow.
  - Adjust this number only if the spout tends to coast past its target position and changes the "Ready" light to yellow.
  - Possible values are 1 to 5.
11. Safety Timer
  - If power is being sent to the motor, but there is no motion being detected by the encoder, a "Motion Error" will occur after a certain length of time. This number determines that length of time.
  - Each number represents  $1/100^{\text{th}}$  of a second (i.e. 50 = .5 seconds; 200 = 2.0 seconds)

### 12. Remote Type

- Use the following chart to determine which remote type is best suited for your application

Setting	Description	Number of Outlets
0	Binary	4 to 24
1	Direct	4 to 8

- See the “External Control” chapter in this manual for information on implementing each remote type
- If you are not using external control, leave this setting at 0.

### 13. Calibration Type

- Set this number to 0 when the encoder is attached to the motor and two proximity switches are used for calibration.
- If the encoder is attached directly to the distributor shaft and no proximity switches are used, set this number to 1.

### 14. Encoder Direction

- If the encoder is counting up when the spout is moving forward, set this number to 0.
- If the encoder is counting down when the spout is moving forward, set this number to 1.

### 15. Use Nicknames

- You can choose to use an alternative numbering system for your outlets.
- Set this number to 0 to disable nicknames.
- Set this number to 1 to enable nicknames.

### 16. Skip Outlets

- If certain outlets are not being used, you can choose to skip those outlets.
- Set this number to 0 to use an outlet.
- Set this number to 1 to skip an outlet

### 17. Nicknames

- You can choose to use an alternative numbering system for your outlets.
- If you are using nicknames, you may enter either the original number or the nickname.
- You may assign any number between 25 and 9999 to any outlet.
- If you have duplicate nicknames, the spout will stop at the highest outlet. Example: If outlet 2 is nicknamed "100" and if outlet 5 is nicknamed "100", when "100" is entered as the outlet to move to, the spout will go to outlet 5.

### 18. Status

- Lists the current values for several variables within the PLC.
- These values are used primarily for troubleshooting.

### 19. Save Settings

- Change this number to 1 to permanently save your settings.
- If you do not save your settings after you make a change, they will be lost when the power is shut off.
- After saving settings, you will be required to calibrate before continuing in run mode.

### ***Calibrate Function***

- Enter the Calibrate Function by pressing the "Calib" button on the Operator Panel.
- You must calibrate:
  1. Every time you power up
  2. Every time you "Save Settings"
- If the power is always on, it is recommended that you calibrate daily to verify that the equipment is functioning properly.
- If any errors are encountered during the Calibration process, a "Calibration Error" is displayed. See "Troubleshooting" for more information.

#### Process

1. The Motor runs in reverse the encoder reaches the index point. This sets the zero reference point.
2. The Motor continues forward until the spout reaches the last usable outlet, and then automatically switches to the Run Function.

### ***Run Function***

- Enter the Run Function by pressing the "Run" button on the Operator Panel.
- The Setup Function and the Calibrate Function need to be completed before you can start the Run Function.

#### Process

1. Press "Enter" to begin input.
2. Use the keypad to enter the number (or nickname) of the outlet that you want to move to.
3. Press "Enter" again.
4. The spout will move to that outlet.
5. When the spout reaches the outlet and is locked into position, the green "Ready" light will turn on and the Distributor will be ready for operation.

### *Remote Function*

- Enter the Remote Function by pressing the "Remote" button on the Operator Panel.
- The Setup Function and the Calibrate Function need to be completed before you can start the Remote Function.
- While in the Remote Function, the bottom line of the display will read "Remote".
- When the green light is on, the top line shows the current outlet and the Distributor is ready for operation.
- See the "External Control" chapter for more information.

### *PLC Message Lamp*

- There are two types of messages on the operator panel: Setup Messages and PLC Messages.
- If the PLC Message lamp is off, you are in the Setup Messages.
- You can alternate between the two types of messages by pressing the "Esc" button.
- It is possible to enter the Setup Messages without pressing the "Setup" button. However, it is advisable to press the "Setup" button before entering "Setup" to clear any functions that are running.
- The panel locks out all key presses for 3 seconds after a PLC Message is displayed in order to ensure the operator has a chance to read the message.

## TROUBLESHOOTING

### Errors

#### **Invalid Entry**

Cause:

- ⊘ Entering a number on the keypad that is too high or too low

Action:

- ⊘ Press the Function button to restart the Function that you were performing.

#### **Calibration Error**

Occurs when an error is encountered during the Calibration process.

Causes:

- ⊘ Loose or incorrect wiring
- ⊘ Faulty Encoder, Speed Reducer, Motor, Starter, or PLC.

Actions:

- ⊘ Check that all wiring is connected properly.
- ⊘ Enter the Manual Function and press an arrow button. If the displayed number changes, the Motor and Encoder are working. If the spout moves, the Motor and Speed Reducer are working.
- ⊘ Stay in the Manual Function and open the Control Enclosure. If you press the “Down” button, the “Y0” light on the PLC should light up, and the reverse side of the Starter should click in. If you press the “Up” button, the “Y1” light on the PLC should light up, and the forward side of the Starter should click in.

<b>Calibration Errors</b>	
<b>Number</b>	<b>Description</b>
1	Arm stays over switch A.
2	Switch B is on when arm is at switch A.
3	Switch B turns on too soon.
4	Arm is past switch B.
5	No usable outlets.

#### **Motion Error**

Occurs when power is being sent to the Motor, but the Encoder isn't registering motion.

Causes:

- ⊘ Debris or ice in Distributor
- ⊘ Loose or faulty wiring.
- ⊘ Faulty Encoder, Motor, Starter, or PLC.

Actions:

- ⊘ Run the Calibration Function. The cause of the error might be cleared.
- ⊘ Open the inspection door on the Distributor check for obstructions.
- ⊘ Check that all wiring is connected properly.

## ***PLC not running***

Symptoms:

- ∄ No lights on Operator Panel.
- ∄ No response when pushing buttons.
- ∄ "Protocol Error" or "PLC Communication Timeout" displayed on Operator Panel.
- ∄ Run light off on the PLC.

Follow these steps to restart the PLC. **Use extreme caution; these steps must be performed with the power on.**

1. Open the door of the Control Enclosure.
2. Look for a light labeled "Run" on the face of the PLC. If the light is off, continue to the next step.
3. Find the small silver switch on the front of the PLC. This is a three-position switch that should be in the center position.
4. Move the switch to the left, then back to the center position.
5. The "Run" light should be on.
6. Close the door of the Control Enclosure.

## ***Emergency Procedures***

If the Motor is not working, disconnect the power, and then loosen the four bolts to drop the Motor and Encoder to the floor of the Drive Enclosure. Insert the Emergency Handle into the Speed Reducer. Each revolution of the Emergency Handle will turn the distributor spout 1/300 of a circle.

## EXTERNAL CONTROL

### ***Preparing for External Control***

1. Your EPC can be controlled from an external source by using the inputs and outputs on the PLC as described in this chapter.
2. The inputs are 12-24 VDC sinking or sourcing.
3. The outputs are 12-24 VDC sinking.
4. You can use power from the 24 VDC power supply in the Control Enclosure.
5. See the "External Control Wiring Diagram" for additional information.

### ***Selecting the Correct Remote Type***

1. Use the following chart to determine which remote type is best suited for your application:

Setting	Description	Number of Outlets
0	Binary	4 to 24
1	Direct	4 to 8

2. The remote type needs to be set using the setup function. See the Setup Function of the Operations chapter of this manual for more details.

### ***Starting the Remote Function***

1. Every time you power up the EPC, you must calibrate before entering the Remote Function.
2. Enter the Remote Function by pressing the "Remote" button on the Operator Panel.
3. The Run Function and the Remote Function operate exclusively of each other. You cannot operate them both at the same time.

### Reading the Outputs

- When the EPC is in the Remote Function, output Y6 will be turned on. This indicates that it is ready to accept a command from the inputs.
- When the spout is in position and the Ready light is green, output Y7 will be turned on. The corresponding value of the current outlet will be turned on in outputs Y10-Y14. This happens whether the EPC is in Remote Function or not.

### PLC Outputs

Description	C1		Binary (Remote Type 0)					Direct (Remote Type 1)							
	Y6	Y7	C2				C3	C2				C3			
	Y6	Y7	Y10	Y11	Y12	Y13	Y14	Y10	Y11	Y12	Y13	Y14	Y15	Y16	Y17
Remote	1														
Ready		1													
Current: 1			1	0	0	0	0	1	0	0	0	0	0	0	0
Current: 2			0	1	0	0	0	0	1	0	0	0	0	0	0
Current: 3			1	1	0	0	0	0	0	1	0	0	0	0	0
Current: 4			0	0	1	0	0	0	0	0	1	0	0	0	0
Current: 5			1	0	1	0	0	0	0	0	0	1	0	0	0
Current: 6			0	1	1	0	0	0	0	0	0	0	1	0	0
Current: 7			1	1	1	0	0	0	0	0	0	0	0	1	0
Current: 8			0	0	0	1	0	0	0	0	0	0	0	0	1
Current: 9			1	0	0	1	0								
Current: 10			0	1	0	1	0								
Current: 11			1	1	0	1	0								
Current: 12			0	0	1	1	0								
Current: 13			1	0	1	1	0								
Current: 14			0	1	1	1	0								
Current: 15			1	1	1	1	0								
Current: 16			0	0	0	0	1								
Current: 17			1	0	0	0	1								
Current: 18			0	1	0	0	1								
Current: 19			1	1	0	0	1								
Current: 20			0	0	1	0	1								
Current: 21			1	0	1	0	1								
Current: 22			0	1	1	0	1								
Current: 23			1	1	1	0	1								
Current: 24			0	0	0	1	1								

0=Off, 1=On

## Setting the Inputs

- When the EPC is in the Remote Function, output Y6 will be turned on. You can send a position command by turning on the corresponding inputs X10-X14. After a one second delay, the spout will start turning, and output Y7 will turn off. You can turn off the inputs any time after output Y7 turns off. When the spout stops turning and is in position, output Y7 will turn back on.
- If the position command you send is the current position, output Y7 will turn off for one second, then turn back on.
- If the position command you send is higher then the number of outlets, or is an outlet that is not used (see Skip Outlets in the Setup Function section of the Operation Chapter), outputs Y6 will turn off, and the display on the operator panel will read "Invalid Entry". The operator will need to press the "Remote" button on the operator panel to restart the remote function.
- All inputs must be turned off before sending another position command.
- If the operator presses "Run" or any other function button on the operator panel, or if an error occurs, output Y6 will turn off.

## PLC Inputs

Description	Binary (Remote Type 0)					Direct (Remote Type 1)							
	C2				C3	C2				C3			
	X10	X11	X12	X13	X14	X10	X11	X12	X13	X14	X15	X16	X17
Move to: 1	1	0	0	0	0	1	0	0	0	0	0	0	0
Move to: 2	0	1	0	0	0	0	1	0	0	0	0	0	0
Move to: 3	1	1	0	0	0	0	0	1	0	0	0	0	0
Move to: 4	0	0	1	0	0	0	0	0	1	0	0	0	0
Move to: 5	1	0	1	0	0	0	0	0	0	1	0	0	0
Move to: 6	0	1	1	0	0	0	0	0	0	0	1	0	0
Move to: 7	1	1	1	0	0	0	0	0	0	0	0	1	0
Move to: 8	0	0	0	1	0	0	0	0	0	0	0	0	1
Move to: 9	1	0	0	1	0								
Move to: 10	0	1	0	1	0								
Move to: 11	1	1	0	1	0								
Move to: 12	0	0	1	1	0								
Move to: 13	1	0	1	1	0								
Move to: 14	0	1	1	1	0								
Move to: 15	1	1	1	1	0								
Move to: 16	0	0	0	0	1								
Move to: 17	1	0	0	0	1								
Move to: 18	0	1	0	0	1								
Move to: 19	1	1	0	0	1								
Move to: 20	0	0	1	0	1								
Move to: 21	1	0	1	0	1								
Move to: 22	0	1	1	0	1								
Move to: 23	1	1	1	0	1								
Move to: 24	0	0	0	1	1								

0=Off, 1=On

*This page intentionally left blank.*

## WARRANTY

The full extent of the warranty supplied by Honeyville Metal, Inc. is to correct any defects in material and/or workmanship on the products manufactured only by Honeyville Metal, Inc. This warranty period extends for **one year** from the date the product arrives on the site where installation will take place. Honeyville Metal, Inc. retains the right to review and/or adjust the time period for those products that may be held in inventory at a dealer's warehouse. Honeyville Metal, Inc. retains the final authority on determining if a product is within the warranty period and if full replacement of that product is required to retain the integrity of our products reputation and meet the customer's expectations. Honeyville Metal, Inc. will not furnish labor for replacement of any defective product or components of a product. Any product that is determined defective by both Honeyville Metal, Inc. and the end user who purchased the product may not be returned to Honeyville Metal, Inc. without the receipt of Return Authorization. Returned products must be shipped to Honeyville Metal, Inc. prepaid unless instructed otherwise and must be clearly marked with a Return Merchandise Authorization (RMA) number that needs to be obtained prior to the return shipment. This warranty supplied by Honeyville Metal, Inc. excludes damage to products while in transit to the destination on all public forms of transportation except the trucking equipment owned and operated by Honeyville Metal, Inc. This warranty does not cover performance guarantees on products, only defects in material and/or workmanship as prior statement. Honeyville Metal, Inc. does honor vendor warranties that extend beyond the one year period and will pass warranty coverage on to the purchaser of that vendor product.

## CERTIFICATE OF QUALITY

Every effort has been made to make this equipment the best value you can obtain for your money. All the components have been inspected and assembled. The complete system has been tested to insure proper operation. We sincerely hope this equipment and our efforts meet with your approval. The full extent of Honeyville Metal, Inc. warranty is to correct any defects in material or workmanship in those products manufactured by Honeyville Metal, Inc. Motors and drives, and all electrical and air control parts carry a one-year warranty.

**READ INSTRUCTIONS CAREFULLY BEFORE OPERATING!**

THIS UNIT WAS FINAL INSPECTED AND PACKED BY \_\_\_\_\_

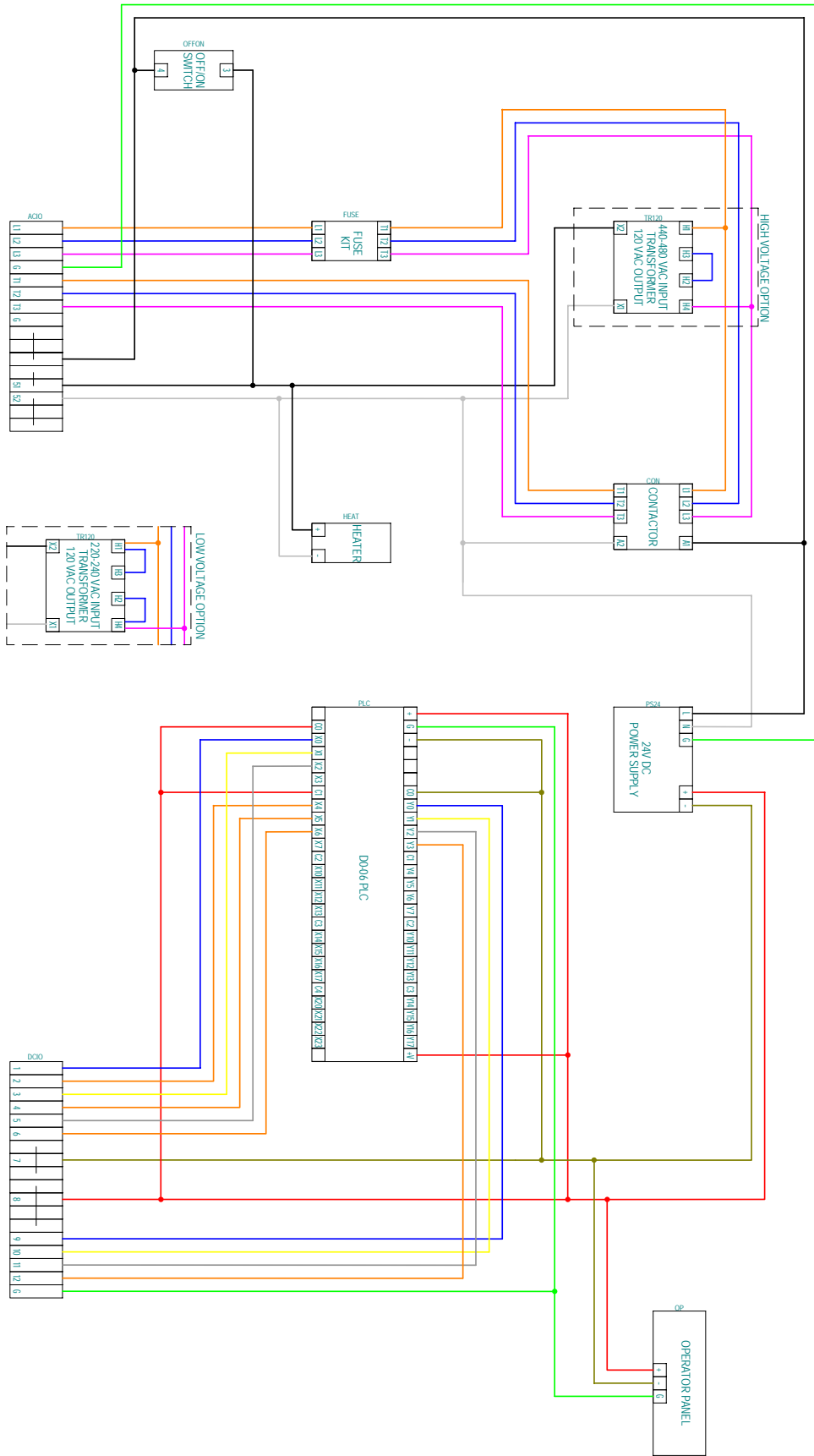

**LEGEND**

Black	White
Orange	Blue
Purple	Green
Yellow	Gray
Brown	

DATE: 3/17/2010	DRAWN BY: CURT	CHECKED BY: MARK	THIS DRAWING AND ALL INFORMATION CONTAINED HEREIN IS THE PROPERTY OF HONEYVILLE METAL, INC., AND IS NOT TO BE REPRODUCED WITHOUT THE EXPRESS WRITTEN PERMISSION OF HMI.  ALL DIMENSIONS MUST BE FIELD VERIFIED BY THE CONTRACTOR. HMI SHALL NOT BE RESPONSIBLE FOR ANY DIMENSIONAL DISCREPANCIES WHICH HAVE NOT BEEN BROUGHT TO THEIR ATTENTION PRIOR TO CONSTRUCTION.  <b>CONTROL ELECTRICAL ENCLOSURE WIRING DIAGRAM</b>  GROUP 2 & 3 DISTRIBUTOR EPC - VERSION 3.1
FILE NAME: CEE Wiring.dft	SHEET NAME: Sheet1		
SHEET: 1 of 1	SCALE: ...	SIZE: B	
DRAWING #:	REV:		

**Honeyville Metal, Inc.**  
 MATERIAL HANDLING EQUIPMENT AND DUST CONTROL SYSTEMS  
 4200 S. 900 W. • TOPEKA, INDIANA 46571  
 PHONE (260) 593-2266 • FAX (260) 593-2486



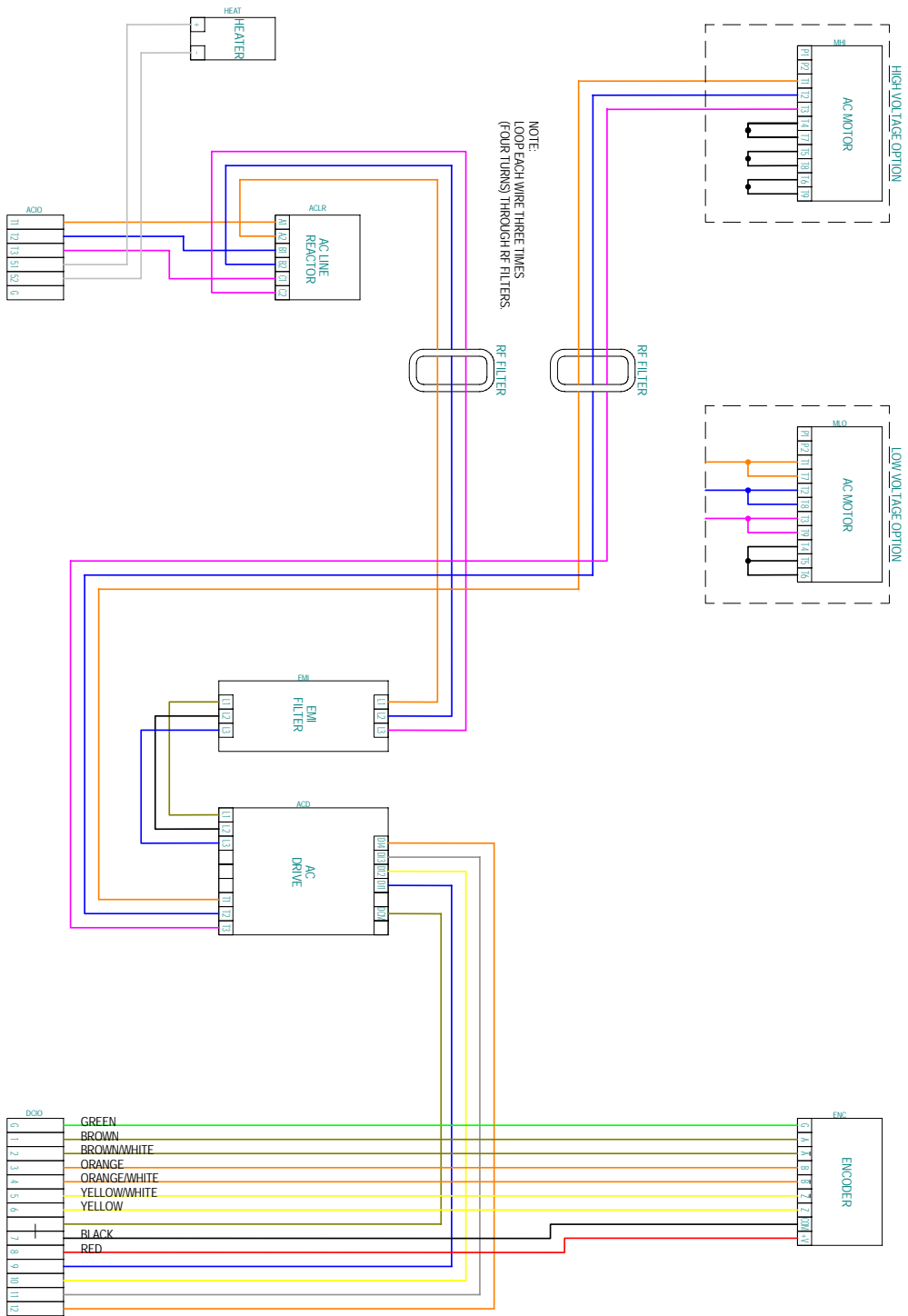

**LEGEND**

Black	BLACK
White	WHITE
Orange	ORANGE
Blue	BLUE
Purple	PURPLE
Green	GREEN
Yellow	YELLOW
Gray	GRAY
Brown	BROWN

DATE: 3/18/2010	DRAWN BY: CURT	CHECKED BY: MARK	THIS DRAWING AND ALL INFORMATION CONTAINED HEREIN IS THE PROPERTY OF HONEYVILLE METAL, INC., AND IS NOT TO BE REPRODUCED WITHOUT THE EXPRESS WRITTEN PERMISSION OF HMI.  ALL DIMENSIONS MUST BE FIELD VERIFIED BY THE CONTRACTOR. HMI SHALL NOT BE RESPONSIBLE FOR ANY DIMENSIONAL DISCREPANCIES WHICH HAVE NOT BEEN BROUGHT TO THEIR ATTENTION PRIOR TO CONSTRUCTION.
FILE NAME: DEE Wiring.dft	SHEET NAME: Sheet1		
SHEET: 1 of 1	SCALE: ...		SIZE: B
DRAWING #:	REV:		GROUP 2 & 3 DISTRIBUTOR EPC - VERSION 3.1

**Honeyville Metal, Inc.**  
 MATERIAL HANDLING EQUIPMENT AND DUST CONTROL SYSTEMS  
 4200 S. 900 W. • TOPEKA, INDIANA 46571  
 PHONE (260) 593-2266 • FAX (260) 593-2486



## D0-06DD1-D I/O Wiring Diagram

These micro PLCs feature twenty DC inputs and sixteen sinking DC outputs. The following diagram shows a typical field wiring example. The DC external power connection uses four terminals at the left as shown.

Inputs are organized into five banks of four. Each bank has an isolated common terminal, and may be wired as either sinking or sourcing inputs. The wiring example below shows all commons connected together, but separate supplies and common circuits may be used.

All outputs actually share the same common. Note the requirement for external power.

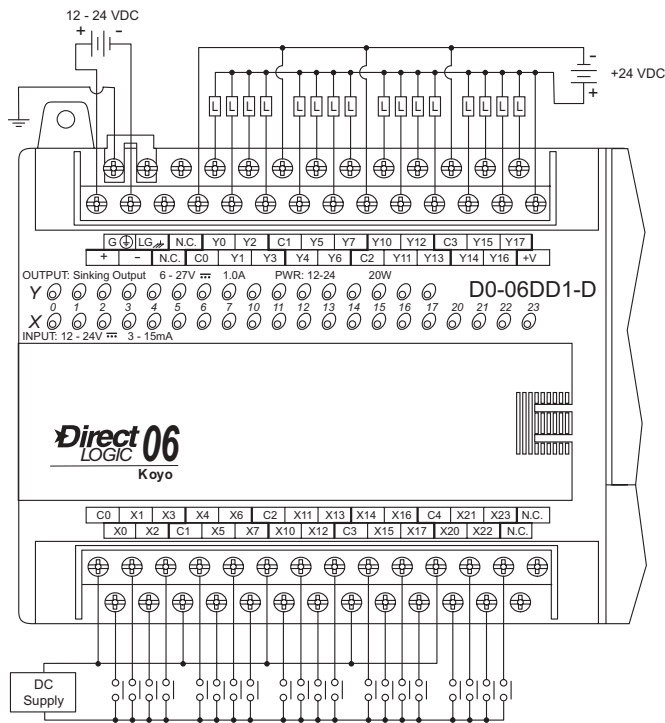

### High Speed Inputs (X0-X3)

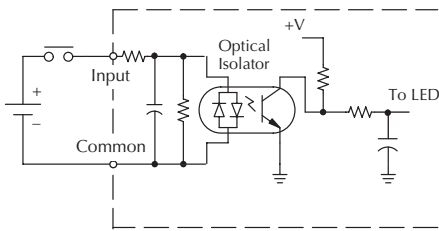

### Standard Input Circuit (X4-X23)

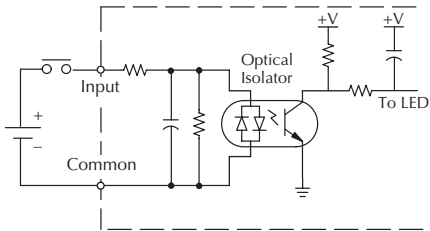

### Derating Chart for DC Outputs

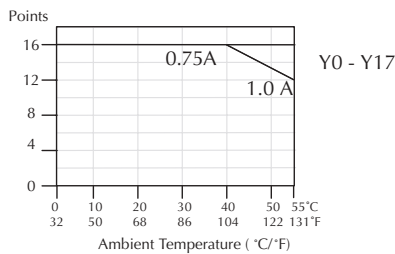

### DC Pulse Outputs (Y0 - Y1)

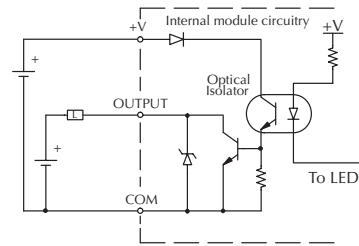

### DC Standard Outputs (Y2 - Y17)

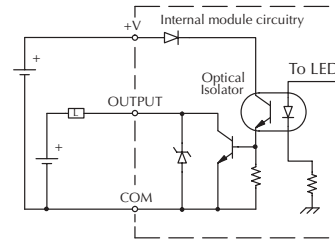

D0-06DD1-D General Specifications		
External Power Requirements	12 – 24 VDC, 20 W maximum,	
Communication Port 1: 9600 baud (Fixed), 8 data bits, 1 stop bit, odd parity	K-Sequence (Slave), DirectNET (Slave), MODBUS (Slave)	
Communication Port 2: 9600 baud (default), 8 data bits, 1 stop bit, odd parity	K-Sequence (Slave), DirectNET (Master/Slave), MODBUS (Master/Slave), Non-sequence/print, ASCII in/out	
Programming cable type	D2-DSCBL	
Operating Temperature	32 to 131° F (0 to 55° C)	
Storage Temperature	-4 to 158° F (-20 to 70° C)	
Relative Humidity	5 to 95% (non-condensing)	
Environmental air	No corrosive gases permitted	
Vibration	MIL STD 810C 514.2	
Shock	MIL STD 810C 516.2	
Noise Immunity	NEMA ICS3-304	
Terminal Type	Removable	
Wire Gauge	One 16 AWG or two 18 AWG, 24 AWG minimum	
DC Input Specifications		
Parameter	High-Speed Inputs, X0 – X3	Standard DC Inputs X4 – X23
Min. - Max. Voltage Range	10.8 – 26.4 VDC	10.8 – 26.4 VDC
Operating Voltage Range	12 – 24 VDC	12 – 24 VDC
Peak Voltage	30 VDC (7 kHz maximum frequency)	30 VDC
Minimum Pulse Width	70 µs	N/A
ON Voltage Level	>10.0 VDC	> 10.0 VDC
OFF Voltage Level	< 2.0 VDC	< 2.0 VDC
Max. Input Current	6mA @12VDC, 13mA @24VDC	4mA @12VDC, 8.5mA @24VDC
Input Impedance	1.8 kΩ @ 12 – 24 VDC	2.8 kΩ @ 12 – 24 VDC
Minimum ON Current	>5 mA	>4 mA
Maximum OFF Current	< 0.5 mA	<0.5 mA
OFF to ON Response	<70 µs	2 – 8 ms, 4 ms typical
ON to OFF Response	<70 µs	2 – 8 ms, 4 ms typical
Status Indicators	Logic side	Logic side
Commons	4 channels / common x 5 banks (isolated)	
DC Output Specifications		
Parameter	Pulse Outputs, Y0 – Y1	Standard Outputs, Y2 – Y17
Min. - Max. Voltage Range	5 – 30 VDC	5 – 30 VDC
Operating Voltage	6 – 27 VDC	6 – 27 VDC
Peak Voltage	< 50 VDC (10 kHz max. frequency)	< 50 VDC
On Voltage Drop	0.3 VDC @ 1 A	0.3 VDC @ 1 A
Max Current (resistive)	0.5 A / pt., 1A / pt. as standard pt.	1.0 A / point
Max leakage current	15 µA @ 30 VDC	15 µA @ 30 VDC
Max inrush current	2 A for 100 ms	2 A for 100 ms
External DC power required	20 - 28 VDC Max 150mA	20 - 28 VDC Max 150mA
OFF to ON Response	< 10 µs	< 10 µs
ON to OFF Response	< 20 µs	< 60 µs
Status Indicators	Logic Side	Logic Side
Commons	4 channels / common x 4 banks (non-isolated)	
Fuses	None (external recommended)	

# *D-90<sup>®</sup> TYPE SE<sup>®</sup> SPEED REDUCERS*

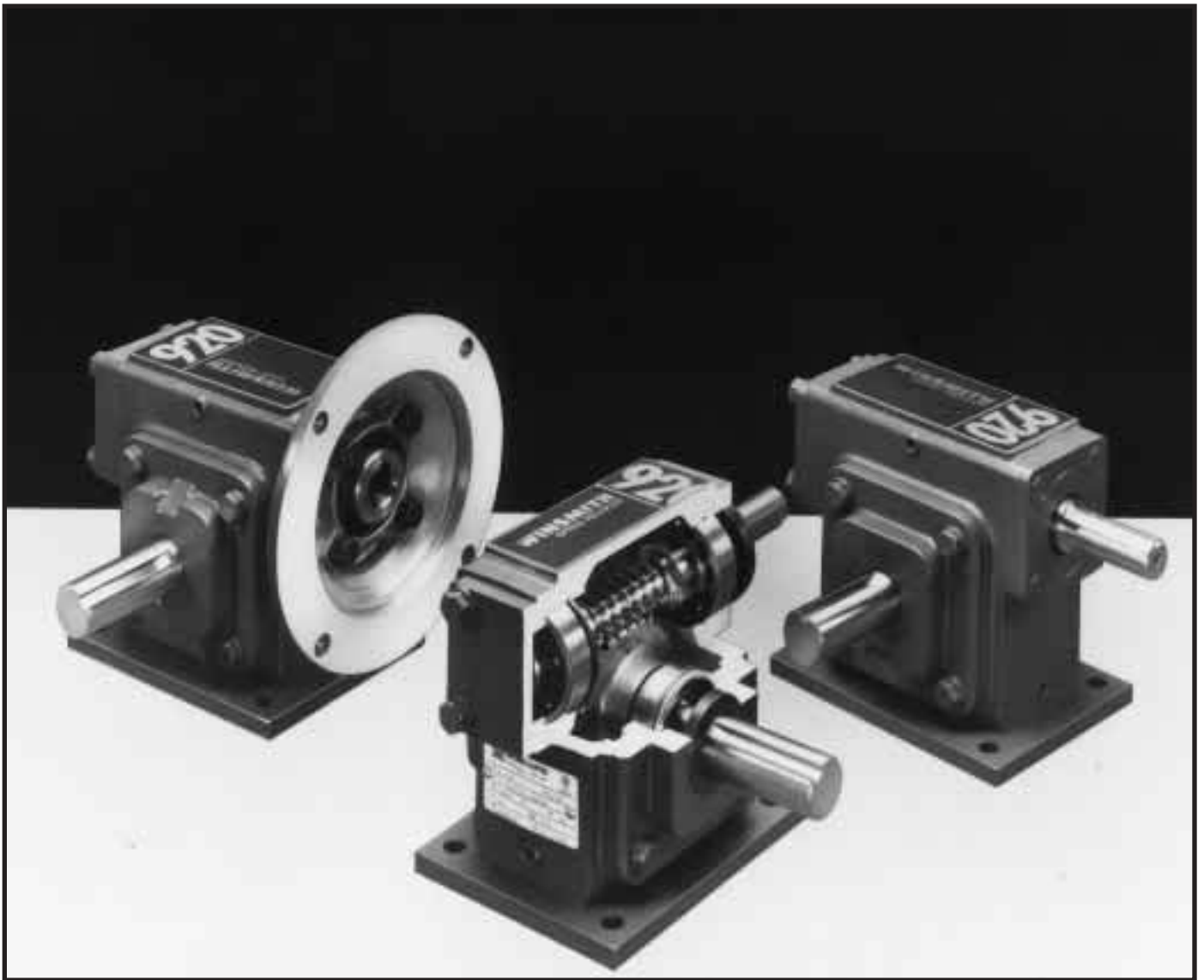

## ***Installation, Operation, and Lubrication Instructions***

## I. SELECTION

The selection of the appropriate speed reducer for a given application requires that all factors affecting the operation of the unit be given careful consideration. Service factors must be applied to catalog ratings depending on the type of prime mover used, severity of the application and duration of daily service. If you have any questions relative to the suitability of your WINSMITH® speed reducer for your particular application, refer to the selection section of the appropriate WINSMITH catalog, or contact your WINSMITH representative or distributor.

## II. INSTALLATION

### 1. Shaft Alignment

- A.** The various drive members (motor, speed reducer, couplings, sprockets, sheaves, gears, etc.) should be aligned as accurately as possible to guard against unusual stresses and overloads imposed by misalignment.
- B.** If a prime mover shaft is to be directly connected to the high speed (input) shaft or if the slow speed (output) shaft is to be directly connected to the driven shaft, flexible couplings should be used. It should be remembered that even flexible couplings have limited ability to accommodate misalignment. Care must be taken at installation to insure that shaft alignments are within the limits recommended by the coupling manufacturer. Use of a rigid coupling to connect speed reducer shafts to other drive components is not recommended as it is almost impossible to obtain exact alignment between two shafts.
- C.** A common base plate supporting the motor and reducer will help preserve the original alignment between reducer and motor shafts. If a structural steel base is used, the plate should be at least equal in thickness to the diameter of the bolts used to fasten the speed reducer to the base plate. Also, for sufficient rigidity, the design in general including angle or channel members should be substantial enough to prevent flexing under vibration. After the first week or two of operation all of the bolts and nuts used to fasten the reducer and motor, pedestal, etc., to the base plate should be retightened. Vibration tends to loosen the nuts even if tight initially. Dowelling the motor and speed reducer to the base plate will help insure that alignment is maintained.

### 2. Mounting Positions

- A.** Single reduction units are designed to accommodate most standard mounting positions. Figure

1 illustrates the utility plug locations for each based on model. All standard single reduction models are equipped with an internal splash shield located near the worm. This shield deflects the oil from the vent, preventing leakage when the vent plug is adjacent to the worm (as on the DT or DV standard mounting). When this location is used as a drain (as on the DV sidewall, worm under), drainage will be better facilitated if done at or near the operating temperature. Filling from this location is not recommended, as the shield will impede the oil flow rate. Bearings are splash lubricated provided the input speed is 1160 RPM or greater. Contact the factory when input speeds fall below this.

- B.** Double reduction models are built to accommodate one mounting position as specified during order entry. Standard mounting positions, furnished unless otherwise specified, are shown in Figure 2 which also illustrates the utility plug locations. Note that the mounting position relates to the main housing orientation. Standard units have an oil level common to both housings and do not use an intermediate oil seal. The vent plug is located in the main housing where the slower worm speed eliminates the need for a vent shield. Grease fittings (not shown in Figure 2) are used to lubricate bearings when oil splash does not serve this purpose (as with the DV or DL upper slow speed bearing).

### 3. Venting

During operation, the heat generated by the gearbox will cause the air and lubricant inside the unit to expand. A vent plug is used to equalize the resulting pressure, the location of which is dependent on the model and mounting position. Before putting the unit into service, review Figures 1 and 2 and relocate the vent plug (if necessary) as shown for the appropriate model and mounting position. Double reduction models (Figure 2) are vented in the main housing only. To prevent loss of oil during shipment, the vent plug includes a brass pin which must be removed prior to operation. If a speed reducer is installed in an atmosphere containing exceptional amounts of moisture or dust, a shielded or hooded vent plug should be used. For intermittent duty applications, where the operating temperature does not rise more than about 20 degrees F, internal pressure build-up is minimal and venting is not necessary. Some models are available with an optional internal expansion chamber allowing units to be totally sealed. Contact us for more details.

## 4. C-Flange Motor Mounting Procedures

### A. Mounting Motor to C-Flange Reducer With Hollow Input Shaft

Check motor and reducer mounting registers for nicks that would interfere with assembly. Remove if necessary.

Remove protective plastic plug from reducer input shaft. The bore has been coated with an anti-seize compound.

Align the motor shaft and key with keyway in bore and slide motor up to flange.

Position the motor conduit box as desired.

Using the fasteners supplied, secure the motor to the reducer. Draw down evenly so as not to bend the motor shaft. Tighten fasteners to 200 inch pounds.

### B. Mounting Motor to C-Flange Reducer With Coupling Adaptor

Check motor and reducer mounting registers for nicks that would interfere with assembly. Remove if necessary.

When assembling the motor and coupling, the coupling halves should be equally spaced on each shaft to insure adequate engagement. The following describes a method for doing this.

First determine the assembled shaft clearance by measuring the distance from the C-Flange face to the reducer shaft end and subtracting the motor shaft length. Mount and secure the motor shaft coupling half with the spider end extending one half the clearance distance beyond the motor shaft. Mount the reducer coupling half and coupling spider on reducer shaft in its approximate position but do not secure.

Locate the motor conduit box in the desired position and secure the motor to the reducer flange using the fasteners provided. Tighten to about 200 inch pounds.

Using the access hole in the flange, slide the coupling together and tighten the set screw.

## 5. Unit Assembly/Disassembly Instructions

Contact the factory for an instruction manual.

# III. LUBRICATION & MAINTENANCE

## 1. Factory Filling

WINSMITH speed reducers are oil filled at the factory to the proper level for the standard mounting

position as shown in Figures 1 or 2. **The oil level should be checked and adjusted (if necessary) prior to operation, using the oil level plug provided and while the unit is oriented in its operating position.**

## 2. Ambient Temperature

If the operating ambient temperature is other than 51-95°F, then refer to lubrication chart and refill the unit with the correct grade based on actual ambient temperatures and operating speed. See item 3 for additional information regarding oil changes.

## 3. Oil Changing

When changing oil for any reason, it should be remembered that oils of various types may not be compatible. Therefore, when changing to a different oil, it is recommended that the housing be completely drained and thoroughly flushed with a light flushing oil prior to refilling with the appropriate lubricant. The oil level should be rechecked after a short period of operation and adjusted, if necessary. When changing double reduction models, each housing should be drained and filled independently, even though there may be a common level.

### A. Initial Oil Change

The oil in a new speed reducer should be changed at the end of 250 hours of operation. (30 days for 8 hour per day service, 15 days for 16 hour service, 10 days for 24 hour service).

### B. Subsequent Oil Changes

Under normal conditions, after the initial oil change, the oil should be changed after every 2500 hours of operation, or every six months, whichever occurs first. Under severe conditions (rapid temperature changes, moist, dirty or corrosive environment) it may be necessary to change oil at intervals of one to three months. Periodic examination of oil samples taken from the unit will help establish the appropriate interval.

### C. Synthetic Oils

Synthetic lubricants can be advantageous over mineral oils in that they generally are more stable, have a longer life, and operate over a wider temperature range. These oils are appropriate for any application but are especially useful when units are subjected to low start-up temperatures or high operating temperatures. However, continuous operation above 225°F may cause damage to seals or other components. It is recommended that the initial oil be changed or filtered after the first 1500 hours of operation to remove metal particles that accumulate during break-in. Subsequent oil

# STANDARD MOUNTING POSITIONS *D-90*<sup>®</sup> TYPE SE<sup>®</sup>

BASIC MODEL	TRADITIONAL MOUNTING	INVERTED MOUNTING	ADDITIONAL MOUNTING POSITIONS			
			INPUT SHAFT HORIZONTAL		INPUT SHAFT VERTICAL	
DB DD DJ DN DT DU WB WT WU						
DV						
DL		<b>SPECIAL</b> Contact the Factory				
DSF			<b>SPECIAL</b> Contact the Factory			
DSN DSR DSU						

Note: Single Reduction 935 and 943 standard models are supplied with grease fittings on the input shaft to insure bearing lubrication for all mounting positions.

= Fill Plug

= Vent Plug

= Level Plug

= Drain Plug

= Grease Fitting

**Figure 1. Single Reduction Models**

DOUBLE REDUCTION* WORM/WORM				DOUBLE REDUCTION* HELICAL/WORM			
OTHER ATTACHMENT HOUSING POSITIONS				OTHER ATTACHMENT HOUSING POSITIONS			

Plug locations apply to motorized units also.

Contact the factory when input speeds are less than 1160 RPM to insure proper lubrication.

\*Double Reduction units are not universal mounting. Mountings other than standard require a special outline.

**Figure 2. Double Reduction Models**

changes should be made after 5000 hours operation if units are operating in a clean environment. This can be extended to 10,000 hours if using new reformulated Mobil SHC lubricants (orange in color) and the lubricant remains free of contamination over this period. See comments under 3B for more severe ambient conditions.

#### 4. Long Term Storage or Infrequent Operation

If a speed reducer is to stand idle for an extended period of time, either prior to installation or during use, it is recommended that the unit be filled completely with oil to protect interior parts from rust corrosion due to internal condensation. Be sure to drain the oil to the proper level before placing the speed reducer in service. A long term storage option is available on new units. Contact us for details.

#### 5. Grease Fittings

Some units are equipped with grease fittings to lubricate bearings not adequately lubricated by the oil splash. These fittings must be lubricated every 3-6 months depending on operating conditions. Bearing greases must be compatible with the type of gear lubricant being used (ie. mineral, synthetic, food grade, etc.) For mineral oils, use a high quality lithium base NLGI #2 bearing grease. For synthetic oils, use a synthetic bearing grease such as Mobil Synthetic Universal grease, Mobilith SHC 100 or a suitable equivalent. For food grade lubricants, use Chevron FM grease, NLGI 2, or equivalent.

#### 6. Low Input Speeds (Under 1160 RPM)

When input speeds are less than 1160 RPM, grease fittings will be required to lubricate any bearings not partially covered by the normal oil level. Such units are considered non-standard and necessitate factory modification. If this low speed operating condition exists and units are without the appropriate grease fittings, please contact the factory.

#### 7. Oil Temperature

Speed reducers in normal operation can generate temperatures up to 200°F depending on the type of reducer and the severity of the application (loading, duration of service, ambient temperatures). Excessive oil temperatures may be the result of one or more of the following factors:

##### A. Overloads

Overloads may be due to the original unit selection being too small for the application, or increased loads on the speed reducer to a point where its rating is exceeded after it has been in service for a period of time. Always check the speed reducer rating when increasing driven loads or increasing the horsepower rating of the motor or other prime mover.

##### B. Overfilling or Underfilling

If a speed reducer is overfilled with oil, the energy used in churning the excessive oil can result in overheating. If this occurs, shut down the drive, remove the oil level plug and allow oil to drain until oil ceases to drain from the level hole, reinstall the oil level plug and restart the drive. If the speed reducer is underfilled, the resultant friction can cause overheating and possible damage. If this occurs, fill the speed reducer to the oil level plug hole and check the gearing for excessive wear.

##### C. Inadequate Cooling

In order to dissipate internally generated heat, the speed reducer must be installed in such a way that air can circulate freely. Tightly confined areas (inside cabinets, etc.) should be avoided. If this is not possible, forced air cooling by means of a separate blower should be used.

#### 8. Oil Seals

Although WINSMITH uses high quality oil seals and precision ground shafts to provide a superior seal contact surface, it is possible that circumstances beyond WINSMITH's control can cause oil seal leakage (damage during shipment or installation, etc.). When replacing a shaft oil seal, using the following suggestions will help to insure leak-free operation and long seal life.

- A.** When installing a new seal, cover the keyway and any other surface discontinuity with smooth tape to protect the seal lip from being damaged.
- B.** A sealant should be used between the O.D. of the seal and the I.D. of the bore into which the seal is installed. The seal bore should also be free of any burrs, nicks, or scratches.
- C.** Be sure that the seal is not cocked in the seal bore. The outer face of the seal should be flush with the surface into which it is mounted.

# Lubricants

## Worm Gear Reducers

For special applications that involve severe ambient temperature extremes or a seasonal oil requirement, WINSMITH, based on extensive testing and field experience, recommends the use of Mobil SHC synthetic lubricants.

Ambient Temperature	-30 to 15°F	16 to 50°F	51 to 95°F	51 to 95°F	96 to 131°F	96 to 131°F
Final Stage Worm Speed*	up to 2000 FPM	up to 2000 FPM	up to 450 FPM	above 450 FPM	up to 450 FPM	above 450 FPM
ISO Viscosity Grade	220	460	680	460	680	460*
AGMA Lubricant No.	5S**	#7 Compounded***	#8 Compounded***	#7 Compounded***	8 S**	7S**

Mobil	SHC 630	600W Super Cylinder	Extra Hecla Super	600W Super Cylinder	SHC 636	SHC 634
American Lubricants	SHC-90W	AGMA #7 Gear Oil	AGMA #8 Gear Oil	AGMA #7 Gear Oil	N/A	N/A
Castrol	Tribol 800/220	Tribol 1105-7C	Tribol 1105-8C	Tribol 1105-7C	Tribol 800/680	Tribol 800/460
Chevron	Tegra 220	Cylinder Oil W460	Cylinder Oil W680	Cylinder Oil W460	Tegra 680	Tegra 460
Conoco	Syncon R & O 220	Inca Oil 460	Inca Oil 680	Inca Oil 460	N/A	Syncon R & O 460
Exxon (Esso)	Teresstic SHP 220	Spartan EP 460	Spartan EP 680	Spartan EP 460	Teresstic SHP 680	Teresstic SHP 460
Fiske Brothers	SPO-MG	SPO-277	SPO-288	SPO-277	N/A	N/A
Shell	Omala RL 220	Valvata J 460	Valvata J 680	Valvata J 460	Omala RL 680	Omala RL 460
Texaco	Pinnacle 220	Vanguard 460	Vanguard 680	Vanguard 460	Pinnacle 680	Pinnacle 460

\*\*synthetic oil

\*\*\*3% to 10% fatty or synthetic oils or mild EP additives

Lubricant selections are provided by the lubricant manufacturer based on AGMA recommended viscosity grades. Viscosity grades are based on Lubrication Standard ANSI/AGMA 9005-D94.

\*The sliding velocity in feet per minute (FPM) for standard ratios is determined by multiplying the speed of the worm in RPM by the factor from the following table. For selecting the proper lubricant, use the speed of the worm in the final stage (input RPM divided by the first stage ratio).

SIZE	Nominal Ratio											
	5	7.5	10	15	20	25	30	40	50	60	80	100
910	0.153	—	0.137	0.133	0.122	0.116	0.132	0.121	0.115	—	—	—
913	0.231	0.189	0.183	0.179	0.171	0.165	0.178	0.169	0.164	0.161	—	—
917	0.303	0.229	0.201	0.193	0.180	0.172	0.189	0.176	0.170	0.166	0.161	0.133
920	0.347	0.263	0.225	0.216	0.202	0.191	0.215	0.200	0.188	0.182	0.164	0.161
924	0.412	0.312	0.261	0.256	0.236	0.223	0.249	0.231	0.216	0.210	0.201	0.196
926	0.455	0.345	0.283	0.276	0.254	0.238	0.269	0.249	0.234	0.225	0.215	0.210
930	0.520	0.395	0.327	0.317	0.291	0.273	0.307	0.285	0.269	0.258	0.246	0.241
935	0.607	0.461	0.427	0.412	0.373	0.349	0.403	0.367	0.345	0.330	0.311	0.299
943	0.633	0.588	0.568	0.553	0.507	0.558	0.544	0.501	0.475	0.457	0.435	0.422



## PEERLESS-WINSMITH, INC.

SPRINGVILLE OPERATIONS • 172 EATON STREET, P.O. BOX 530, SPRINGVILLE, NY 14141-0530

PHONE: 716/592-9310 • FAX: 716/592-9546

<http://www.winsmith.com> e-mail=winsmith@winsmith.com

