



# EFM Series Pulse-Jet Filters



10 Sizes – Ranging from 2,500 to 38,700 CFM





Pulse Valve Enclosure

High Entry Inlet & Velocity Drop Chamber

Particulate Deflector Baffles

Explosion Relief Panel

60° 2-Way Sloped Hopper

Service Ladder & Perimeter Safety Railing

Clean Air Plenum Service Enclosure

No-Tool Top Bag & Cage Removal

Rectangular Clean Air Outlet

16 oz. Polyester Bag w/ Mirror Finish & Galvanized Wire Cages

All-Bolted Construction G-90 Galvanized Steel Formed Panels

No-Tool Removal Hopper Inspection Cover



# HONEYVILLE EFM SERIES PULSE-JET MODULAR BAGHOUSE FILTER

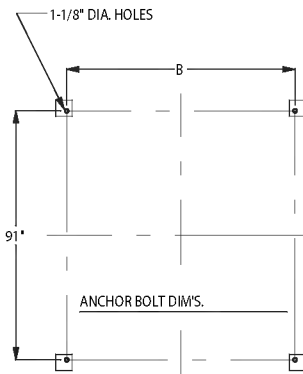
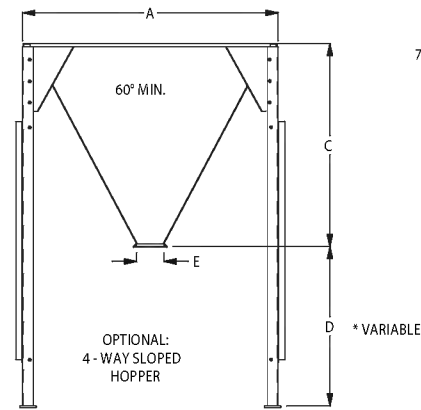
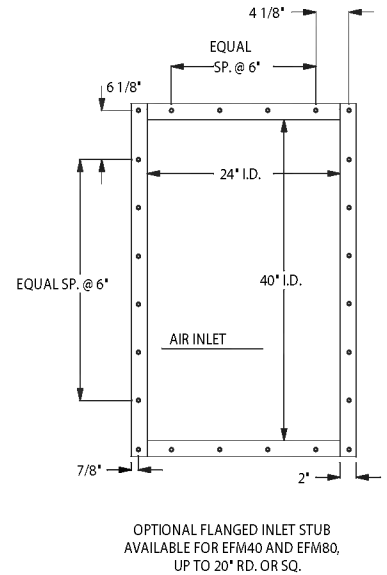
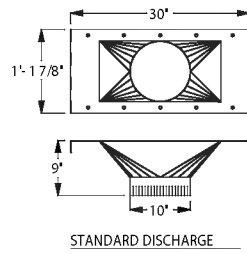
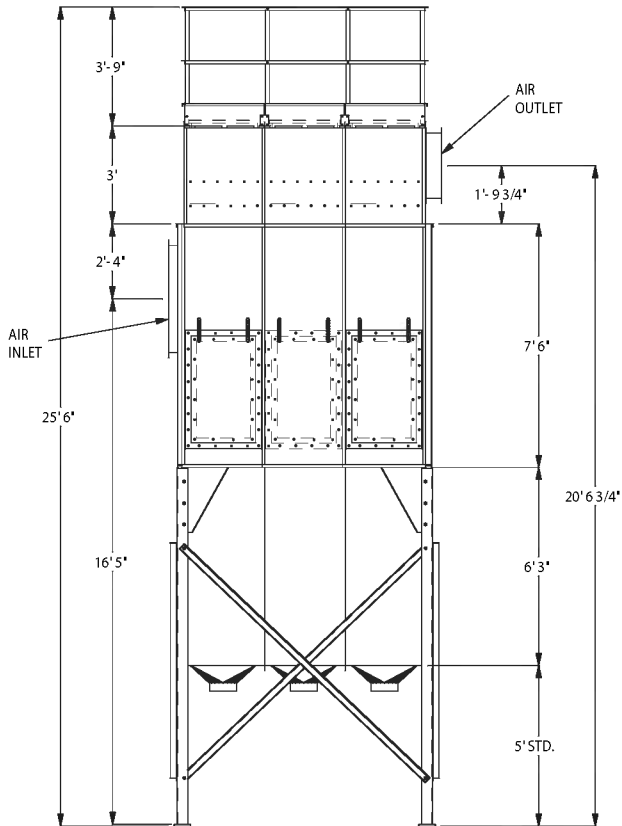
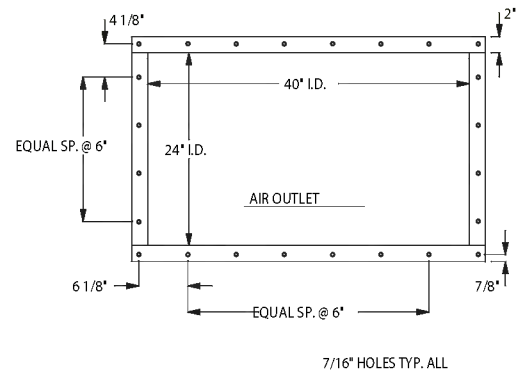
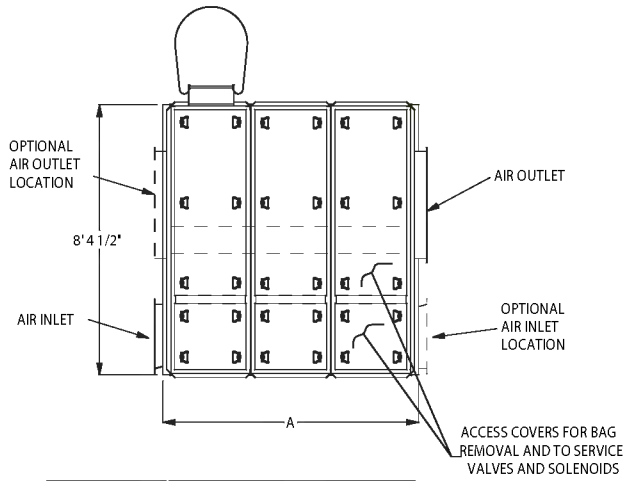

## EFM FILTER GENERAL INFORMATION

MODEL	NO. OF BAGS	NO. OF VALVES	SQ. FT. CLOTH	COMP. AIR SCFM	NO. OF EXPLOS. PANELS	FOOT PLATE	GENERAL DIM'S. (INCHES)				
							A	B	C	D	E
EFM40	40	4	387	7/10	1	6 X 6	34-1/2	28	76	54*	10
EFM80	80	8	774	10/12	2	6 X 6	64-1/2	58	76	54*	10
EFM120	120	12	1,161	12/20	3	8 X 8	94-1/2	88	76	60*	12
EFM160	160	16	1,548	20/30	4	8 X 8	124-1/2	118	96	66*	16
EFM200	200	20	1,935	25/30	5	8 X 8	154-1/2	148	116	66*	16
EFM240	240	24	2,322	30/40	6	8 X 8	184-1/2	178	—	—	—
EFM280	280	28	2,709	35/40	7	8 X 8	214-1/2	208	—	—	—
EFM320	320	32	3,096	40/50	8	8 X 8	244-1/2	238	—	—	—
EFM360	360	36	3,483	45/55	9	8 X 8	277-1/2	268	—	—	—
EFM400	400	40	3,870	50/60	10	8 X 8	304-1/2	298	—	—	—

## EFM FILTER DESCRIBED

**HONEYVILLE EFM MODULAR FILTERS** are designed for Heavy Duty load applications with Dust Conditions either as an After Filter or a Primary Baghouse Filter. The Filter utilizes Pulse-Jet Cleaning of the Bags and also provides NO-TOOL TOP BAG REMOVAL for inspection or service.

**THE EFM MODULAR FILTER** will effectively filter such materials as Grain, Feed, Flour, Sugar, Various Cement Products, and all types of Wood Waste.

**THE EFM FILTER OPERATES AS FOLLOWS:** Dust laden air enters the Filter at a High Side Entry. Large Particles will drop directly into the Hopper due to the Velocity Drop upon entry. Small Dust Particles pass laterally into the Bag area through a Baffle System designed to trap particles as the turn is made. Dust is retained on the exterior of the Bags. The Clean Air flows upward through the Bags and exits via the open top of the Bags into the Clean Air Plenum. This air may be vented outside or inside a building.

**BAG CLEANING IS CONTROLLED BY AN ELECTRONIC TIMER.** Upon activation by the Timer, a Diaphragm Valve discharges the volume of the Supply Manifold for an adjustable period of time. Compressed air exits the Manifold and travels into one of several Pulse Pipes that have Air Nozzles located directly above each Bag. As the compressed air enters the Bag, filtration is momentarily stopped. The compressed air bubble travels down the length of each Bag moving the fabric and dust away from the Cage. When the Bag reaches its elastic limit, movement is stopped while the dust continues to move away from the Bag surface and is discharged into the base of the Filter.

**EFM FILTERS HAVE MINIMAL MOVING PARTS** thus operating with a minimal amount of maintenance. The Timer Control is completely adjustable in regards to cycle and pulse duration to minimize compressed air usage. Clean, dry air at 90 to 95 PSI must be supplied. All units are equipped with a Magnahelic Gauge providing a constant reading of resistance due to dust build up on the Bags.

Manufactured by



4200S 900W • Topeka, IN 46571  
Phone (800) 593-8377 • Fax (260) 593-2486  
[www.honeyvillemetal.com](http://www.honeyvillemetal.com)