

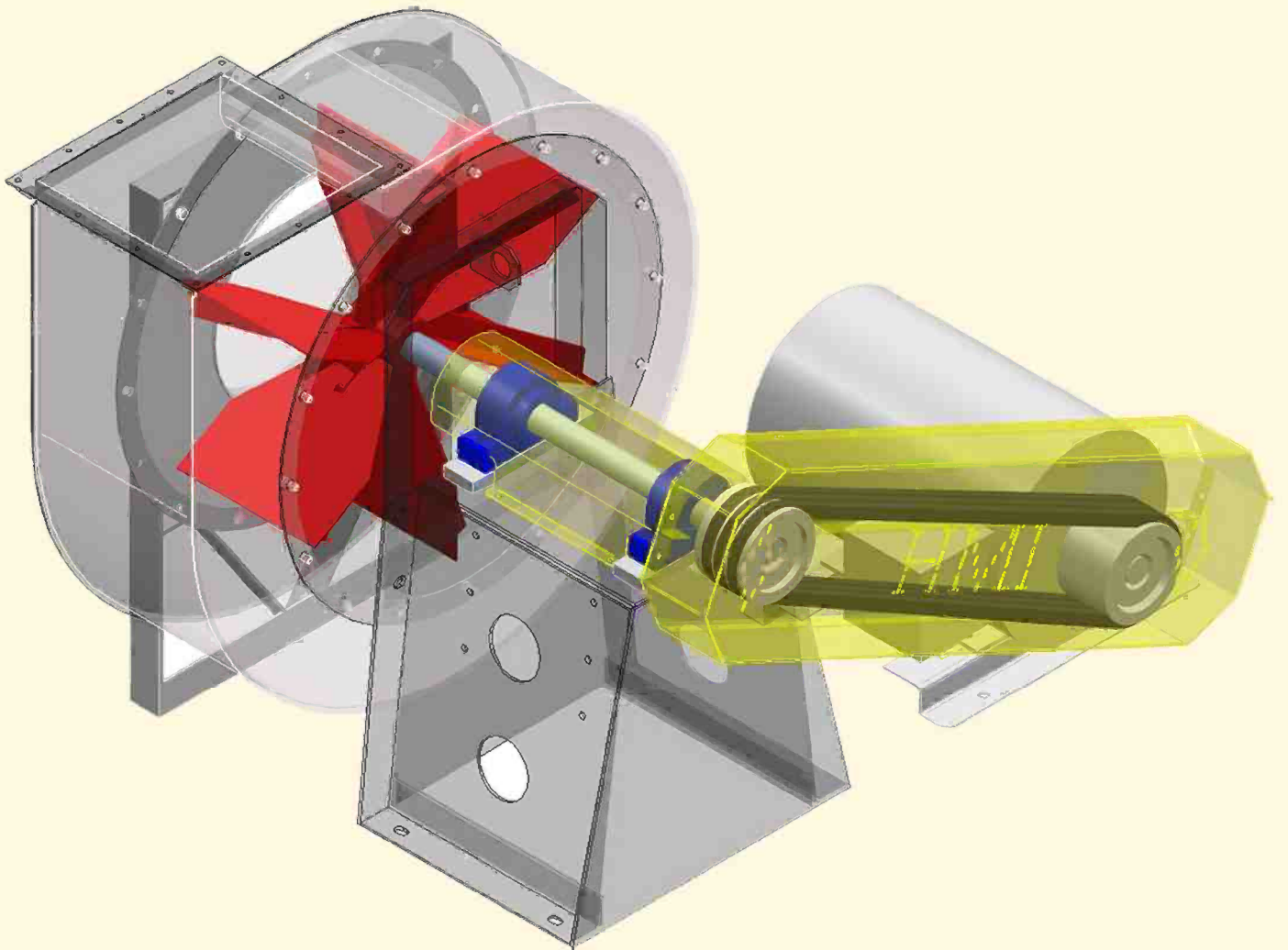

***Honeyville***

**HF Series  
Fans**



# Honeyville HF Series Material Handling Fans



**H**oneyville Material Handling Fans range in size from 6" to 41" with a capacity range from 500 to 58,500 CFM. We manufacture our fans out of a variety of steel thicknesses to meet your specific needs. With our own in-house balancing machine, we have the means to provide you with a balancing service that is second to none. Next day turn around on balancing wheels is the norm, rather than the exception.

## Fan Wheel Design

- Self-cleaning paddles with an open face for minimal material build-up.
- Eight-paddle design on 6" and 8" fans. Six-paddle wheel design on 9" to 41" fans.
- All fan wheels are statically and dynamically balanced in-house.

## Shaft Material

- CF1045 turned, ground and polished steel shafting.

## Scroll Housing

- Solid weld construction.
- 16 different arrangements in clockwise or counter-clockwise orientation

## Arrangement

- All HF Series fans are available in arrangement number 9. Other arrangements are available on some sizes.

## Inlets

- Standard round, straight collar inlet on 6" to 17" fans.
- Standard round, flanged inlet on 19" to 41" fans.

## Outlets

- Standard rectangular, flanged outlets proportionally sized to the inlets.

## Drain Plugs

- Standard on 9" fans and larger. Optional on the 6" and 8" fans.

## Steel Material Options

- Standard Duty (STD) Designed for dry, nonabrasive material with 3/16" or smaller particulate size.
- Heavy Duty (HD) Paddles are 1/8" thicker than on the standard duty fan. Designed for semi-dry, mildly-abrasive material with 3/8" or smaller particulate size.
- Extra Heavy Duty (XHD) Paddles are 1/4" thicker than on the standard duty fan. Designed for wet, abrasive material with 3/4" or smaller particulate size.
- Extra Heavy Duty Abrasion Resistant (XHD-AR) Paddles are constructed of 1/2" AR400F. Designed for wet, highly-abrasive material with 5/8" or smaller particulate size.

















## Other Options

- Stainless Steel Construction.
- Housing access cover
- Flanged inlets on 17" and smaller fans.



Honeyville Metal Incorporated certifies that the HF Series Material Handling Fans shown on pages 3-17 are licensed to bear the AMCA Seal. The ratings shown are based on tests and procedures in accordance with AMCA Publication 211 and comply with the requirements of the AMCA Certified Ratings Program.

# Designation for Rotation and Discharge of Centrifugal Fans

 Clockwise Up Blast CW 360	 Clockwise Top Angular Up CW 45	 Clockwise Top Horizontal CW 90	 Clockwise Top Angular Down CW 135	 Clockwise Down Blast CW 180	 Clockwise Bottom Angular Down CW 225	 Clockwise Bottom Horizontal CW 270	 Clockwise Bottom Angular Up CW 315
 Counterclockwise Up Blast CCW 360	 Counterclockwise Top Angular Up CCW 45	 Counterclockwise Top Horizontal CCW 90	 Counterclockwise Top Angular Down CCW 135	 Counterclockwise Down Blast CCW 180	 Counterclockwise Bottom Angular Down CCW 225	 Counterclockwise Bottom Horizontal CCW 270	 Counterclockwise Bottom Angular Up CCW 315

## Notes:

1. Direction of rotation and angular reference is determined from the drive side. Drive side is the side opposite fan inlet.
2. Direction of discharge is determined in accordance with diagrams. Angle of discharge is referred to the top vertical axis of fan and designated in degrees as measured in the direction of fan rotation. Angle of discharge may be any intermediate angle as required.
3. A fan inverted for ceiling suspension or rotated for side wall mounting will have its direction of rotation and angle of discharge determined when fan is located as if floor mounted.
4. This standard is in harmony with ISO 13349. In ISO 13349, CCW fans are referred to as LG, i.e., Left or Gauche, while CW fans are referred to as RD, i.e., Right or Droit-handed rotation.

Adapted from ANSI/AMCA Standard 99-10,  
Standards Handbook, with the express written  
permission from the Air Movement and Control  
Association International Inc.  
30 West University Drive  
Arlington Heights, IL 60004-1893



**Inlet Size: 6" Outside Diameter**  
**Inlet Area: 0.182 Sq. Ft.**  
**Max Safe Fan Speed: 5,195 RPM**

# Model HF6

**Outlet Size: 4-1/4" x 5-1/2" Outside**  
**Outlet Area: 0.148 Sq. Ft.**

**Wheel Diameter: 12-1/2"**  
**Wheel Circumference: 3.27 Feet**  
**Tip Speed (FPM): 3.27 x RPM**

SP		0.5"		1"		1.5"		2"		2.5"		3"		3.5"		4"		4.5"		5"	
OV	CFM	RPM	BHP	RPM	BHP	RPM	BHP	RPM	BHP	RPM	BHP	RPM	BHP	RPM	BHP	RPM	BHP	RPM	BHP	RPM	BHP
1000	148	834	0.03	1107	0.06	1332	0.09	1532	0.12	1708	0.16	1867	0.20	2013	0.24	2149	0.28	2277	0.33	2399	0.38
1200	178	880	0.04	1136	0.07	1353	0.10	1541	0.14	1716	0.18	1875	0.22	2021	0.27	2157	0.31	2285	0.36	2406	0.41
1400	207	930	0.04	1176	0.08	1378	0.11	1564	0.16	1729	0.20	1883	0.24	2030	0.29	2166	0.34	2294	0.39	2414	0.45
1600	237	981	0.06	1222	0.09	1417	0.13	1588	0.18	1752	0.22	1902	0.27	2040	0.32	2174	0.37	2302	0.43	2423	0.48
1800	266	1035	0.07	1270	0.11	1458	0.15	1627	0.20	1777	0.25	1925	0.30	2063	0.35	2191	0.40	2311	0.46	2431	0.52
2000	296	1096	0.09	1320	0.13	1506	0.17	1667	0.22	1817	0.28	1952	0.33	2085	0.38	2214	0.44	2334	0.50	2448	0.56
2200	326	1160	0.10	1371	0.15	1554	0.20	1713	0.25	1857	0.31	1992	0.36	2117	0.42	2237	0.48	2357	0.55	2471	0.61
2400	355	1224	0.13	1424	0.18	1604	0.23	1761	0.28	1900	0.34	2032	0.40	2156	0.46	2272	0.53	2382	0.59	2494	0.66
2600	385	1290	0.15	1480	0.20	1655	0.26	1809	0.32	1948	0.38	2075	0.44	2196	0.51	2312	0.57	2421	0.64	2524	0.71
2800	414	1354	0.18	1542	0.24	1708	0.30	1859	0.36	1997	0.42	2123	0.49	2239	0.55	2352	0.62	2460	0.70	2563	0.77
3000	444	1420	0.21	1605	0.27	1761	0.33	1911	0.40	2046	0.47	2171	0.54	2287	0.61	2396	0.68	2501	0.75	2603	0.83
3200	474	1486	0.24	1669	0.31	1817	0.38	1963	0.45	2096	0.51	2220	0.59	2335	0.66	2443	0.74	2545	0.82	2644	0.90
3400	503	1553	0.28	1734	0.36	1879	0.43	2016	0.50	2148	0.57	2270	0.65	2384	0.72	2491	0.81	2593	0.89	2689	0.97
3600	533	1621	0.33	1799	0.41	1942	0.48	2070	0.55	2200	0.63	2321	0.71	2433	0.79	2540	0.87	2641	0.96	2737	1.04
3800	562	1692	0.37	1863	0.46	2005	0.54	2130	0.61	2254	0.69	2373	0.78	2484	0.86	2589	0.95	2690	1.03	2785	1.12
4000	592	1765	0.43	1928	0.52	2070	0.60	2193	0.68	2308	0.76	2425	0.85	2536	0.94	2639	1.02	2739	1.12	2834	1.21
4200	622	1839	0.49	1993	0.58	2135	0.67	2256	0.76	2367	0.84	2479	0.93	2588	1.02	2691	1.11	2789	1.20	2883	1.30
4400	651	1913	0.55	2060	0.65	2201	0.75	2319	0.84	2429	0.92	2533	1.01	2641	1.11	2743	1.20	2840	1.30	2933	1.39
4600	681	1987	0.62	2126	0.72	2265	0.82	2384	0.92	2492	1.01	2593	1.10	2694	1.20	2796	1.30	2892	1.40	2984	1.50
4800	710	2061	0.70	2194	0.80	2329	0.91	2449	1.01	2555	1.11	2655	1.20	2749	1.30	2849	1.40	2944	1.51	3036	1.61
5000	740	2137	0.78	2262	0.88	2394	1.00	2515	1.11	2619	1.21	2717	1.31	2810	1.41	2903	1.51	2997	1.62	3088	1.73
5200	770	2212	0.87	2330	0.97	2460	1.09	2579	1.21	2684	1.32	2780	1.42	2872	1.53	2959	1.63	3051	1.74	3141	1.85
5400	799	2288	0.96	2403	1.07	2526	1.19	2643	1.32	2749	1.43	2844	1.54	2935	1.65	3021	1.76	3105	1.86	3194	1.98
5600	829	2363	1.06	2476	1.18	2593	1.30	2708	1.43	2815	1.55	2909	1.67	2998	1.78	3083	1.89	3165	2.00	3248	2.12
5800	858	2440	1.17	2549	1.29	2660	1.42	2773	1.55	2879	1.68	2973	1.80	3062	1.92	3146	2.03	3227	2.15	3304	2.26
6000	888	2516	1.29	2622	1.41	2728	1.54	2839	1.68	2943	1.81	3039	1.94	3126	2.06	3209	2.19	3289	2.30	3366	2.42
6200	918	2593	1.41	2696	1.54	2796	1.67	2905	1.81	3008	1.95	3105	2.09	3191	2.22	3273	2.34	3352	2.47	3428	2.59
6400	947	2669	1.55	2771	1.68	2865	1.81	2972	1.96	3073	2.10	3169	2.25	3256	2.38	3337	2.51	3415	2.64	3491	2.77
6600	977	2746	1.69	2845	1.82	2938	1.96	3039	2.11	3139	2.26	3233	2.41	3322	2.55	3402	2.69	3479	2.82	3554	2.95
6800	1006	2823	1.84	2920	1.98	3011	2.12	3106	2.26	3204	2.42	3298	2.58	3387	2.73	3467	2.87	3543	3.01	3617	3.14

SP		5.5"		6"		7"		8"		9"		10"		11"		12"		13"		14"	
OV	CFM	RPM	BHP	RPM	BHP	RPM	BHP	RPM	BHP	RPM	BHP	RPM	BHP	RPM	BHP	RPM	BHP	RPM	BHP	RPM	BHP
2000	296	2557	0.62	2664	0.69	2871	0.83	3064	0.97	3244	1.12	3415	1.27	3578	1.43	3734	1.59	3883	1.75	4026	1.92
2200	326	2579	0.68	2683	0.74	2879	0.88	3072	1.03	3253	1.18	3424	1.34	3586	1.51	3742	1.68	3891	1.85	4034	2.02
2400	355	2602	0.73	2705	0.80	2900	0.94	3082	1.09	3261	1.25	3432	1.42	3595	1.59	3750	1.76	3899	1.94	4043	2.12
2600	385	2625	0.78	2728	0.86	2923	1.01	3105	1.17	3275	1.32	3440	1.49	3603	1.67	3758	1.85	3907	2.04	4051	2.23
2800	414	2662	0.84	2756	0.92	2946	1.08	3127	1.24	3298	1.41	3459	1.58	3612	1.75	3767	1.94	3916	2.13	4059	2.33
3000	444	2701	0.91	2795	0.99	2972	1.15	3150	1.32	3320	1.49	3482	1.67	3635	1.85	3781	2.04	3924	2.23	4067	2.43
3200	474	2741	0.98	2834	1.06	3011	1.23	3175	1.40	3343	1.58	3504	1.77	3658	1.96	3804	2.15	3945	2.34	4080	2.54
3400	503	2781	1.05	2875	1.14	3050	1.31	3214	1.49	3369	1.67	3527	1.87	3680	2.06	3827	2.26	3967	2.47	4102	2.67
3600	533	2828	1.13	2916	1.22	3090	1.40	3254	1.59	3408	1.78	3554	1.97	3703	2.17	3850	2.38	3990	2.59	4125	2.80
3800	562	2876	1.21	2964	1.31	3131	1.49	3294	1.68	3448	1.88	3594	2.08	3733	2.29	3873	2.50	4013	2.72	4148	2.94
4000	592	2924	1.30	3011	1.40	3176	1.59	3334	1.79	3488	1.99	3633	2.20	3772	2.41	3905	2.63	4036	2.85	4171	3.08
4200	622	2973	1.40	3060	1.50	3224	1.70	3378	1.90	3528	2.11	3673	2.32	3811	2.54	3944	2.77	4071	2.99	4194	3.22
4400	651	3022	1.50	3109	1.60	3272	1.81	3425	2.02	3570	2.23	3713	2.45	3851	2.68	3984	2.91	4111	3.14	4233	3.37
4600	681	3072	1.60	3158	1.71	3320	1.92	3473	2.14	3617	2.36	3754	2.58	3891	2.82	4023	3.05	4150	3.29	4272	3.54
4800	710	3123	1.71	3208	1.82	3369	2.05	3521	2.27	3665	2.50	3801	2.73	3932	2.96	4063	3.21	4190	3.45	4312	3.70
5000	740	3175	1.83	3258	1.94	3419	2.17	3570	2.41	3713	2.64	3849	2.88	3978	3.12	4104	3.36	4230	3.62	4352	3.88
5200	770	3227	1.96	3310	2.08	3469	2.30	3619	2.55	3761	2.79	3896	3.04	4026	3.29	4150	3.53	4271	3.79	4392	4.05
5400	799	3280	2.10	3362	2.21	3519	2.45	3668	2.69	3810	2.95	3945	3.20	4074	3.46	4197	3.72	4317	3.97	4433	4.24
5600	829	3333	2.24	3415	2.36	3571	2.60	3718	2.85	3859	3.11	3994	3.37	4122	3.64	4245	3.90	4364	4.17	4479	4.44
5800	858	3387	2.39	3468	2.51	3623	2.76	3769	3.01	3909	3.28	4043	3.55	4171	3.82	4293	4.10	4412	4.37	4526	4.65
6000	888	3441	2.54	3522	2.67	3676	2.93	3821	3.19	3959	3.45	4092	3.73	4220	4.01	4342	4.29	4460	4.58	4574	4.86
6200	918	3502	2.71	3576	2.84	3729	3.11	3873	3.38	4010	3.64	4142	3.92	4269	4.21	4391	4.50	4508	4.79	4622	5.09
6400	947	3563	2.89	3634	3.02	3782	3.29	3926	3.57	4062	3.84	4193	4.12	4319	4.41	4440	4.71	4557	5.02	4670	5.32
6600	977	3626	3.08	3696	3.21	3836	3.48	3979	3.77	4114	4.05	4244	4.34	4369	4.63	4490	4.93	4606	5.24	4719	5.55
6800	1006	3688	3.28	3758	3.41	3891	3.68	4032	3.98	4167	4.27	4296	4.56	4420	4.86	4539	5.16	4656	5.48	4768	5.80

SP - Static Pressure Inches H<sub>2</sub>O

OV - Outlet Velocity In Feet Per Minute

CFM - Cubic Feet Per Minute

Power rating (BHP) does not include transmission losses. Performance ratings do not include the effects of appurtenances (accessories). All capacities are based on standard air (density 0.075 #/cu. ft. 70° F. 29.92" Hg. Bar.). Performances shown in the color zone are those operating at maximum static efficiency. Performance certified is for installation type D - Ducted inlet, Ducted outlet.

Inlet Size: 8" Outside Diameter

Inlet Area: 0.331 Sq. Ft.

Max Safe Fan Speed: 4,725 RPM

Model HF8

Outlet Size: 5-3/4" x 7-1/4" Outside

Outlet Area: 0.270 Sq. Ft.

Wheel Diameter: 13-3/4"

Wheel Circumference: 3.60 Feet

Tip Speed (FPM): 3.60 x RPM

Table with columns for SP (OV, CFM), RPM, BHP for outlet sizes 0.5", 1", 1.5", 2", 2.5", 3", 3.5", 4", 4.5", 5".

Table with columns for SP (OV, CFM), RPM, BHP for outlet sizes 5.5", 6", 7", 8", 9", 10", 11", 12", 13", 14".

SP - Static Pressure Inches H2O

OV - Outlet Velocity In Feet Per Minute

CFM - Cubic Feet Per Minute

Power rating (BHP) does not include transmission losses. Performance ratings do not include the effects of appurtenances (accessories). All capacities are based on standard air (density 0.075 #/cu. ft. 70° F. 29.92" Hg. Bar.). Performances shown in the color zone are those operating at maximum static efficiency. Performance certified is for installation type D - Ducted inlet, Ducted outlet.



**Inlet Size: 9" Outside Diameter**  
**Inlet Area: 0.421 Sq. Ft.**  
**Max Safe Fan Speed: 4,190 RPM**

# Model HF9

**Outlet Size: 8" x 9-1/16" Outside**  
**Outlet Area: 0.478 Sq. Ft.**

**Wheel Diameter: 15-1/2"**  
**Wheel Circumference: 4.06 Feet**  
**Tip Speed (FPM): 4.06 x RPM**

SP		1"		2"		3"		4"		5"		6"		7"		8"		9"		10"	
OV	CFM	RPM	BHP	RPM	BHP	RPM	BHP	RPM	BHP	RPM	BHP	RPM	BHP	RPM	BHP	RPM	BHP	RPM	BHP	RPM	BHP
1000	478	924	0.15	1261	0.31	1532	0.50	1762	0.70	1964	0.91	2148	1.14	2316	1.38	2476	1.67	2627	1.97	2769	2.29
1200	574	953	0.19	1282	0.36	1542	0.56	1772	0.78	1974	1.02	2157	1.27	2325	1.53	2482	1.80	2629	2.08	2768	2.37
1400	669	986	0.23	1305	0.42	1563	0.64	1782	0.87	1983	1.13	2166	1.39	2335	1.67	2491	1.96	2638	2.26	2778	2.57
1600	765	1022	0.27	1333	0.49	1585	0.73	1803	0.98	1996	1.24	2176	1.52	2344	1.82	2501	2.13	2648	2.45	2787	2.78
1800	860	1067	0.33	1363	0.57	1610	0.82	1825	1.09	2017	1.37	2191	1.67	2354	1.97	2510	2.30	2657	2.64	2796	2.99
2000	956	1114	0.40	1398	0.65	1639	0.93	1848	1.21	2039	1.51	2213	1.83	2373	2.15	2522	2.48	2667	2.84	2806	3.21
2200	1052	1165	0.47	1434	0.74	1669	1.04	1877	1.35	2061	1.66	2234	2.00	2394	2.34	2543	2.70	2683	3.06	2816	3.42
2400	1147	1220	0.56	1474	0.85	1703	1.16	1906	1.49	2089	1.83	2256	2.17	2416	2.54	2565	2.92	2705	3.30	2837	3.69
2600	1243	1277	0.66	1521	0.97	1739	1.30	1936	1.65	2119	2.01	2285	2.38	2438	2.75	2586	3.15	2726	3.55	2858	3.96
2800	1338	1334	0.77	1569	1.10	1776	1.44	1972	1.81	2148	2.19	2314	2.59	2467	2.98	2609	3.38	2748	3.81	2880	4.24
3000	1434	1395	0.90	1617	1.25	1820	1.61	2008	1.99	2181	2.40	2343	2.81	2496	3.23	2638	3.65	2772	4.08	2902	4.53
3200	1530	1458	1.04	1671	1.41	1867	1.79	2044	2.18	2217	2.61	2374	3.04	2525	3.49	2667	3.94	2800	4.39	2927	4.84
3400	1625	1521	1.20	1727	1.59	1914	2.00	2087	2.40	2253	2.84	2410	3.29	2555	3.75	2696	4.23	2830	4.71	2956	5.19
3600	1721	1586	1.37	1783	1.78	1963	2.21	2133	2.64	2290	3.08	2446	3.56	2590	4.04	2726	4.53	2859	5.04	2985	5.54
3800	1816	1651	1.57	1841	2.00	2014	2.45	2180	2.90	2333	3.35	2482	3.84	2626	4.35	2760	4.86	2888	5.38	3014	5.91
4000	1912	1717	1.78	1899	2.22	2069	2.70	2228	3.18	2379	3.65	2519	4.13	2662	4.66	2796	5.20	2922	5.74	3044	6.29
4200	2008	1783	2.01	1959	2.48	2125	2.97	2277	3.47	2426	3.97	2564	4.47	2698	4.99	2832	5.56	2958	6.12	3077	6.69
4400	2103	1850	2.26	2022	2.75	2182	3.26	2329	3.78	2474	4.31	2610	4.84	2738	5.35	2868	5.93	2994	6.52	3113	7.11
4600	2199	1918	2.53	2085	3.05	2239	3.58	2384	4.12	2522	4.67	2658	5.22	2784	5.76	2905	6.32	3030	6.93	3149	7.55
4800	2294	1986	2.84	2149	3.37	2297	3.91	2440	4.48	2571	5.05	2705	5.63	2831	6.20	2949	6.76	3066	7.36	3185	8.01
5000	2390	2056	3.16	2213	3.72	2355	4.27	2496	4.87	2626	5.46	2754	6.05	2878	6.65	2995	7.24	3107	7.83	3221	8.48
5200	2486	2125	3.51	2278	4.09	2417	4.66	2553	5.27	2681	5.89	2802	6.50	2926	7.13	3042	7.75	3153	8.36	3258	8.97
5400	2581	2195	3.89	2343	4.48	2480	5.08	2611	5.70	2737	6.34	2856	6.98	2974	7.63	3090	8.27	3200	8.91	3305	9.55
5600	2677	2265	4.29	2405	4.87	2543	5.53	2669	6.16	2794	6.82	2911	7.49	3023	8.15	3138	8.82	3247	9.49	3351	10.15
5800	2772	2336	4.72	2475	5.35	2607	6.00	2727	6.64	2851	7.33	2966	8.02	3075	8.70	3186	9.40	3295	10.09	3398	10.78
6000	2868	2406	5.19	2542	5.83	2671	6.50	2789	7.16	2908	7.86	3022	8.58	3130	9.29	3235	10.00	3343	10.72	3446	11.44
6200	2964	2477	5.68	2609	6.34	2735	7.03	2852	7.72	2966	8.43	3079	9.17	3186	9.90	3288	10.63	3391	11.37	3493	12.12
6400	3059	2548	6.20	2676	6.87	2800	7.60	2915	8.31	3024	9.02	3136	9.78	3242	10.54	3343	11.30	3440	12.05	3542	12.82
6600	3155	2620	6.75	2744	7.45	2866	8.19	2979	8.93	3085	9.65	3193	10.43	3298	11.22	3398	12.00	3494	12.77	3590	13.56
6800	3250	2691	7.34	2813	8.06	2931	8.82	3043	9.58	3147	10.33	3251	11.10	3355	11.92	3454	12.72	3549	13.53	3640	14.33

SP		11"		12"		13"		14"		15"		16"		17"		18"		19"		20"	
OV	CFM	RPM	BHP	RPM	BHP	RPM	BHP	RPM	BHP	RPM	BHP	RPM	BHP	RPM	BHP	RPM	BHP	RPM	BHP	RPM	BHP
2000	956	2938	3.58	3065	3.97	3186	4.36	3303	4.76	3415	5.17	3524	5.59	3630	6.01	3732	6.44	3832	6.87	3929	7.32
2200	1052	2948	3.82	3074	4.23	3195	4.64	3312	5.06	3425	5.49	3534	5.92	3639	6.37	3742	6.82	3841	7.27	3938	7.73
2400	1147	2963	4.08	3084	4.49	3205	4.92	3322	5.36	3434	5.81	3543	6.26	3649	6.73	3751	7.20	3851	7.67	3948	8.15
2600	1243	2984	4.38	3105	4.80	3220	5.23	3331	5.66	3444	6.13	3553	6.61	3658	7.09	3761	7.58	3860	8.07	3957	8.58
2800	1338	3006	4.68	3126	5.13	3241	5.58	3352	6.03	3460	6.50	3563	6.96	3668	7.46	3770	7.97	3870	8.48	3967	9.00
3000	1434	3027	4.99	3148	5.46	3263	5.94	3374	6.41	3481	6.90	3585	7.39	3685	7.88	3783	8.38	3879	8.89	3976	9.44
3200	1530	3049	5.31	3169	5.81	3285	6.30	3395	6.80	3502	7.31	3606	7.82	3706	8.34	3804	8.86	3899	9.38	3991	9.91
3400	1625	3076	5.67	3191	6.16	3306	6.68	3417	7.20	3524	7.73	3628	8.27	3728	8.80	3825	9.35	3920	9.90	4013	10.45
3600	1721	3105	6.05	3220	6.56	3330	7.08	3439	7.61	3546	8.16	3649	8.72	3750	9.28	3847	9.85	3942	10.42	4034	10.99
3800	1816	3134	6.44	3249	6.98	3359	7.52	3465	8.06	3568	8.60	3671	9.18	3771	9.77	3869	10.36	3963	10.95	4056	11.55
4000	1912	3164	6.84	3278	7.41	3388	7.97	3494	8.54	3596	9.11	3696	9.68	3792	10.25	3890	10.88	3985	11.49	4077	12.11
4200	2008	3193	7.26	3307	7.85	3417	8.44	3523	9.03	3625	9.62	3724	10.22	3820	10.82	3914	11.42	4007	12.05	4099	12.69
4400	2103	3227	7.70	3337	8.30	3447	8.92	3552	9.54	3654	10.16	3753	10.78	3849	11.40	3942	12.03	4033	12.65	4121	13.28
4600	2199	3262	8.17	3371	8.79	3476	9.41	3582	10.06	3684	10.70	3782	11.35	3878	12.00	3971	12.65	4062	13.30	4150	13.95
4800	2294	3298	8.65	3406	9.30	3511	9.94	3611	10.59	3713	11.26	3812	11.94	3907	12.61	4000	13.29	4091	13.96	4179	14.64
5000	2390	3334	9.15	3442	9.82	3546	10.49	3646	11.17	3743	11.84	3841	12.54	3937	13.24	4030	13.94	4120	14.64	4208	15.35
5200	2486	3371	9.67	3478	10.37	3582	11.06	3682	11.76	3779	12.46	3873	13.16	3966	13.88	4059	14.61	4149	15.34	4237	16.07
5400	2581	3407	10.20	3515	10.93	3618	11.65	3718	12.38	3814	13.10	3908	13.83	3999	14.56	4089	15.29	4179	16.05	4267	16.80
5600	2677	3451	10.81	3551	11.51	3655	12.26	3754	13.01	3850	13.76	3944	14.51	4034	15.27	4122	16.02	4208	16.78	4296	17.56
5800	2772	3498	11.47	3593	12.15	3691	12.88	3790	13.66	3886	14.44	3979	15.22	4070	16.00	4158	16.78	4244	17.56	4327	18.34
6000	2868	3545	12.15	3640	12.86	3732	13.56	3827	14.33	3923	15.14	4016	15.94	4106	16.75	4194	17.55	4279	18.36	4363	19.17
6200	2964	3592	12.86	3687	13.59	3778	14.32	3866	15.05	3959	15.86	4052	16.69	4142	17.52	4230	18.35	4315	19.19	4398	20.02
6400	3059	3639	13.59	3734	14.35	3825	15.11	3913	15.87	3998	16.62	4089	17.45	4178	18.31	4266	19.17	4351	20.03	4434	20.89
6600	3155	3687	14.35	3781	15.14	3872	15.93	3959	16.71	4044	17.49	4127	18.26	4215	19.13	4302	20.01	4387	20.90	4470	21.79
6800	3250	3736	15.15	3829	15.96	3919	16.77	4006	17.58	4091	18.39	4173	19.19	4253	19.98	4339	20.88	4424	21.79	4506	22.70

SP - Static Pressure Inches H<sub>2</sub>O

OV - Outlet Velocity In Feet Per Minute

Inlet Size: 11" Outside Diameter

Inlet Area: 0.634 Sq. Ft.

Max Safe Fan Speed: 3,420 RPM

# Model HF11

Outlet Size: 9-7/16" x 10-3/4" Outside

Outlet Area: 0.666 Sq. Ft.

Wheel Diameter: 19"

Wheel Circumference: 4.97 Feet

Tip Speed (FPM): 4.97 x RPM

SP	1"		2"		3"		4"		5"		6"		7"		8"		9"		10"		
	OV	CFM	RPM	BHP	RPM	BHP	RPM	BHP	RPM	BHP	RPM	BHP	RPM	BHP	RPM	BHP	RPM	BHP	RPM	BHP	
1000	666	759	0.22	1052	0.49	1273	0.78	1459	1.10	1625	1.45	1774	1.82	1912	2.21	2040	2.63	2160	3.06	2274	3.51
1200	799	774	0.25	1064	0.56	1286	0.89	1473	1.23	1637	1.60	1786	1.99	1923	2.41	2051	2.85	2172	3.31	2285	3.79
1400	932	793	0.30	1072	0.61	1300	1.00	1486	1.38	1650	1.78	1799	2.19	1935	2.63	2063	3.09	2183	3.57	2297	4.07
1600	1066	818	0.35	1085	0.67	1308	1.07	1500	1.53	1664	1.96	1812	2.41	1949	2.87	2076	3.35	2195	3.85	2308	4.37
1800	1199	845	0.41	1104	0.76	1317	1.15	1509	1.63	1678	2.14	1826	2.63	1963	3.13	2090	3.64	2209	4.17	2322	4.71
2000	1332	884	0.50	1123	0.85	1332	1.25	1517	1.72	1686	2.26	1839	2.84	1977	3.39	2103	3.93	2223	4.49	2335	5.06
2200	1465	923	0.59	1149	0.96	1351	1.39	1528	1.84	1695	2.39	1848	2.98	1988	3.61	2117	4.23	2237	4.82	2349	5.43
2400	1598	965	0.70	1175	1.08	1371	1.52	1547	2.01	1704	2.51	1856	3.13	1997	3.78	2128	4.46	2251	5.16	2363	5.80
2600	1732	1012	0.84	1205	1.21	1395	1.68	1566	2.19	1722	2.72	1865	3.28	2005	3.95	2136	4.65	2259	5.38	2375	6.13
2800	1865	1061	0.99	1244	1.38	1421	1.85	1586	2.37	1741	2.94	1881	3.51	2014	4.13	2145	4.85	2268	5.60	2384	6.37
3000	1998	1110	1.16	1284	1.57	1447	2.03	1611	2.59	1760	3.17	1901	3.77	2030	4.39	2153	5.05	2276	5.82	2392	6.62
3200	2131	1160	1.36	1324	1.77	1479	2.25	1636	2.81	1781	3.41	1920	4.04	2049	4.69	2169	5.35	2285	6.04	2401	6.86
3400	2264	1211	1.57	1366	2.00	1518	2.50	1662	3.05	1807	3.68	1939	4.32	2068	5.00	2188	5.69	2301	6.39	2409	7.11
3600	2398	1256	1.78	1413	2.26	1557	2.77	1690	3.31	1832	3.96	1963	4.63	2088	5.33	2208	6.05	2321	6.78	2427	7.52
3800	2531	1302	2.00	1461	2.56	1597	3.07	1728	3.63	1858	4.26	1989	4.96	2109	5.67	2227	6.42	2340	7.18	2447	7.95
4000	2664	1348	2.24	1510	2.87	1638	3.38	1767	3.98	1885	4.57	2015	5.31	2135	6.05	2247	6.80	2359	7.59	2466	8.40
4200	2797	1394	2.50	1559	3.22	1681	3.74	1807	4.35	1923	4.98	2041	5.67	2160	6.45	2272	7.23	2379	8.01	2485	8.85
4400	2930	1441	2.78	1609	3.59	1729	4.14	1847	4.75	1962	5.40	2068	6.05	2186	6.86	2298	7.67	2403	8.49	2505	9.32
4600	3064	1488	3.09	1659	3.99	1777	4.57	1887	5.17	2001	5.86	2106	6.54	2213	7.28	2324	8.13	2429	8.98	2528	9.84
4800	3197	1536	3.42	1710	4.42	1825	5.04	1930	5.63	2041	6.34	2145	7.05	2242	7.76	2350	8.61	2455	9.50	2554	10.39
5000	3330	1584	3.77	1756	4.83	1874	5.53	1977	6.15	2081	6.84	2184	7.59	2281	8.33	2376	9.11	2481	10.03	2580	10.95
5200	3463	1637	4.18	1801	5.26	1924	6.06	2025	6.71	2121	7.38	2224	8.16	2320	8.93	2410	9.70	2507	10.57	2606	11.53
5400	3596	1689	4.62	1847	5.71	1973	6.62	2073	7.31	2165	7.97	2264	8.76	2359	9.56	2449	10.36	2534	11.16	2632	12.14
5600	3730	1742	5.09	1893	6.19	2024	7.22	2122	7.94	2213	8.63	2304	9.38	2399	10.23	2488	11.06	2573	11.88	2658	12.76
5800	3863	1795	5.60	1939	6.70	2074	7.86	2171	8.61	2260	9.33	2345	10.04	2439	10.92	2527	11.78	2612	12.64	2692	13.50
6000	3996	1848	6.13	1986	7.24	2123	8.50	2220	9.31	2309	10.07	2392	10.80	2479	11.64	2567	12.54	2651	13.44	2731	14.32
6200	4129	1902	6.70	2033	7.81	2168	9.12	2270	10.06	2357	10.85	2439	11.61	2520	12.40	2607	13.34	2690	14.26	2770	15.18
6400	4262	1955	7.31	2080	8.41	2213	9.76	2320	10.85	2406	11.67	2487	12.47	2564	13.25	2647	14.16	2730	15.13	2809	16.08
6600	4396	2009	7.96	2128	9.04	2259	10.44	2370	11.68	2455	12.53	2535	13.36	2612	14.17	2688	15.03	2770	16.02	2848	17.01
6800	4529	2063	8.64	2175	9.71	2305	11.16	2421	12.56	2505	13.44	2584	14.30	2659	15.14	2732	15.97	2810	16.96	2888	17.98

SP	11"		12"		13"		14"		15"		16"		17"		18"		19"		20"		
	OV	CFM	RPM	BHP	RPM	BHP	RPM	BHP	RPM	BHP	RPM	BHP	RPM	BHP	RPM	BHP	RPM	BHP	RPM	BHP	
2000	1332	2443	5.65	2545	6.25	2643	6.86	2738	7.48	2829	8.11	2918	8.78	3005	9.46	3088	10.16	3170	10.86	3249	11.58
2200	1465	2456	6.05	2559	6.68	2657	7.32	2752	7.97	2843	8.63	2931	9.31	3017	9.99	3100	10.69	3181	11.42	3261	12.16
2400	1598	2470	6.45	2573	7.11	2671	7.79	2766	8.47	2857	9.17	2945	9.88	3031	10.59	3114	11.32	3194	12.06	3273	12.80
2600	1732	2484	6.87	2587	7.56	2685	8.27	2779	8.98	2871	9.71	2959	10.45	3044	11.20	3127	11.96	3208	12.73	3287	13.51
2800	1865	2494	7.17	2600	7.99	2699	8.76	2793	9.51	2885	10.27	2973	11.04	3058	11.82	3141	12.61	3222	13.41	3301	14.22
3000	1998	2503	7.44	2608	8.28	2710	9.14	2807	10.03	2899	10.83	2987	11.63	3072	12.45	3155	13.27	3236	14.10	3315	14.95
3200	2131	2511	7.70	2617	8.57	2718	9.46	2816	10.36	2910	11.29	3001	12.24	3086	13.09	3169	13.94	3250	14.81	3329	15.68
3400	2264	2520	7.98	2626	8.86	2727	9.77	2824	10.70	2918	11.65	3009	12.62	3097	13.61	3183	14.62	3264	15.52	3342	16.43
3600	2398	2529	8.27	2634	9.16	2735	10.09	2833	11.04	2927	12.02	3018	13.01	3106	14.02	3192	15.05	3275	16.09	3356	17.16
3800	2531	2548	8.73	2646	9.52	2744	10.42	2841	11.39	2935	12.39	3026	13.40	3114	14.43	3200	15.48	3283	16.55	3364	17.64
4000	2664	2567	9.21	2665	10.03	2758	10.86	2850	11.74	2944	12.76	3035	13.79	3123	14.85	3209	15.92	3292	17.01	3373	18.12
4200	2797	2587	9.70	2684	10.55	2777	11.41	2867	12.28	2953	13.15	3043	14.19	3132	15.27	3217	16.36	3300	17.48	3381	18.61
4400	2930	2606	10.20	2703	11.09	2796	11.98	2886	12.88	2972	13.78	3056	14.70	3140	15.69	3226	16.81	3309	17.95	3390	19.10
4600	3064	2625	10.72	2722	11.64	2815	12.56	2905	13.49	2991	14.43	3075	15.38	3156	16.33	3235	17.28	3317	18.42	3399	19.59
4800	3197	2649	11.28	2742	12.20	2835	13.16	2924	14.12	3010	15.09	3094	16.07	3175	17.05	3254	18.04	3331	19.04	3407	20.10
5000	3330	2674	11.88	2765	12.81	2854	13.77	2943	14.76	3030	15.77	3113	16.78	3194	17.80	3273	18.82	3350	19.85	3424	20.88
5200	3463	2700	12.49	2790	13.46	2877	14.43	2963	15.42	3049	16.46	3133	17.50	3214	18.55	3292	19.61	3369	20.67	3443	21.73
5400	3596	2726	13.13	2816	14.13	2903	15.13	2986	16.14	3069	17.17	3152	18.24	3233	19.33	3311	20.41	3388	21.51	3462	22.61
5600	3730	2752	13.79	2842	14.82	2928	15.86	3012	16.90	3092	17.94	3171	19.00	3252	20.11	3331	21.24	3407	22.36	3482	23.49
5800	3863	2778	14.46	2868	15.53	2954	16.60	3037	17.68	3118	18.75	3196	19.83	3272	20.92	3350	22.07	3427	23.23	3501	24.40
6000	3996	2808	15.21	2894	16.26	2980	17.37	3063	18.48	3143	19.59	3221	20.70	3297	21.82	3370	22.94	3446	24.12	3520	25.32
6200	4129	2846	16.10	2920	17.02	3006	18.16	3089	19.30	3169	20.45	3247	21.59	3322	22.75	3396	23.90	3467	25.05	3540	26.26
6400	4262	2885	17.03	2958	17.97	3032	18.97	3115	20.15	3195	21.33	3273	22.51	3348	23.69	3421	24.88	3493	26.07	3562	27.26
6600	4396	2924	17.99	2997	18.97	3067	19.94	3141	21.02	3221	22.23	3299	23.45	3374	24.67	3447	25.89	3518	27.11	3588	28.34
6800	4529	2963	19.00	3036	20.00	3106	21.01	3173	22.01	3248	23.16	3325	24.41	3400	25.67						



Inlet Size: 13" Outside Diameter

Inlet Area: 0.891 Sq. Ft.

Max Safe Fan Speed: 2,885 RPM

# Model HF13

Outlet Size: 11-1/8" x 12-7/8" Outside

Outlet Area: 0.949 Sq. Ft.

Wheel Diameter: 22-1/2"

Wheel Circumference: 5.89 Feet

Tip Speed (FPM): 5.89 x RPM

SP		1"		2"		3"		4"		5"		6"		7"		8"		9"		10"	
OV	CFM	RPM	BHP	RPM	BHP	RPM	BHP	RPM	BHP	RPM	BHP	RPM	BHP	RPM	BHP	RPM	BHP	RPM	BHP	RPM	BHP
1000	949	623	0.28	862	0.65	1043	1.09	1195	1.58	1331	2.08	1455	2.60	1569	3.14	1675	3.71	1775	4.30	1869	4.92
1200	1139	642	0.35	872	0.72	1054	1.18	1206	1.70	1341	2.27	1462	2.88	1576	3.47	1682	4.09	1781	4.72	1876	5.38
1400	1329	664	0.43	881	0.80	1065	1.28	1218	1.82	1352	2.42	1474	3.06	1585	3.74	1689	4.45	1788	5.15	1883	5.85
1600	1518	688	0.50	898	0.92	1074	1.40	1229	1.96	1364	2.57	1485	3.24	1597	3.94	1701	4.69	1798	5.46	1891	6.27
1800	1708	715	0.59	919	1.07	1084	1.53	1238	2.12	1374	2.75	1497	3.43	1608	4.16	1712	4.93	1810	5.73	1902	6.57
2000	1898	748	0.72	942	1.22	1104	1.73	1247	2.28	1383	2.94	1506	3.64	1620	4.38	1724	5.17	1821	6.01	1913	6.87
2200	2088	783	0.85	966	1.37	1125	1.95	1264	2.51	1392	3.15	1516	3.88	1629	4.65	1735	5.44	1833	6.29	1925	7.18
2400	2278	817	1.00	991	1.54	1147	2.18	1285	2.80	1407	3.41	1525	4.12	1638	4.92	1744	5.75	1843	6.61	1936	7.49
2600	2467	851	1.17	1020	1.74	1171	2.41	1306	3.10	1428	3.76	1538	4.42	1647	5.21	1753	6.07	1852	6.96	1946	7.87
2800	2657	886	1.35	1054	1.99	1196	2.65	1328	3.40	1449	4.13	1559	4.84	1661	5.56	1762	6.39	1861	7.32	1955	8.27
3000	2847	921	1.56	1088	2.25	1221	2.91	1352	3.71	1470	4.51	1580	5.27	1681	6.04	1776	6.81	1870	7.68	1964	8.67
3200	3037	960	1.80	1122	2.54	1252	3.23	1377	4.03	1493	4.88	1601	5.73	1702	6.54	1797	7.36	1886	8.18	1973	9.08
3400	3227	1001	2.07	1156	2.85	1286	3.60	1402	4.36	1518	5.27	1623	6.19	1723	7.06	1818	7.93	1906	8.80	1990	9.67
3600	3416	1042	2.38	1190	3.18	1319	3.99	1430	4.76	1542	5.67	1647	6.63	1745	7.61	1839	8.52	1927	9.44	2011	10.36
3800	3606	1084	2.71	1225	3.53	1354	4.41	1463	5.22	1567	6.10	1672	7.10	1769	8.13	1860	9.14	1948	10.11	2032	11.08
4000	3796	1127	3.08	1260	3.91	1389	4.86	1497	5.72	1595	6.58	1696	7.60	1793	8.66	1883	9.74	1970	10.80	2053	11.82
4200	3986	1170	3.48	1295	4.32	1422	5.32	1531	6.25	1628	7.16	1721	8.11	1817	9.22	1907	10.35	1992	11.48	2074	12.59
4400	4176	1213	3.92	1332	4.77	1456	5.81	1565	6.82	1661	7.77	1750	8.71	1842	9.81	1932	10.98	2016	12.16	2097	13.35
4600	4365	1256	4.39	1373	5.29	1491	6.34	1600	7.42	1695	8.42	1783	9.40	1867	10.42	1956	11.63	2041	12.86	2121	14.09
4800	4555	1300	4.90	1414	5.84	1526	6.90	1634	8.04	1730	9.10	1817	10.14	1898	11.16	1981	12.31	2065	13.59	2145	14.87
5000	4745	1345	5.46	1455	6.44	1561	7.49	1668	8.68	1764	9.83	1850	10.91	1931	11.98	2008	13.05	2090	14.34	2170	15.67
5200	4935	1390	6.06	1497	7.08	1596	8.12	1702	9.36	1799	10.59	1885	11.72	1965	12.84	2041	13.95	2115	15.12	2194	16.50
5400	5125	1435	6.71	1539	7.76	1634	8.80	1737	10.08	1833	11.36	1919	12.58	1999	13.75	2074	14.90	2145	16.05	2219	17.35
5600	5314	1480	7.40	1581	8.49	1674	9.58	1772	10.84	1867	12.17	1954	13.48	2033	14.69	2107	15.90	2178	17.10	2246	18.29
5800	5504	1526	8.14	1624	9.27	1715	10.40	1807	11.64	1901	13.02	1988	14.39	2067	15.68	2141	16.94	2212	18.18	2279	19.42
6000	5694	1572	8.93	1667	10.10	1757	11.27	1843	12.48	1935	13.92	2022	15.34	2102	16.72	2175	18.02	2245	19.32	2312	20.60
6200	5884	1618	9.78	1710	10.97	1798	12.19	1879	13.38	1970	14.85	2056	16.33	2136	17.79	2210	19.16	2279	20.50	2346	21.83
6400	6074	1664	10.67	1754	11.90	1840	13.16	1920	14.39	2005	15.83	2090	17.36	2170	18.88	2245	20.34	2314	21.73	2380	23.11
6600	6263	1710	11.63	1797	12.88	1882	14.19	1961	15.47	2041	16.86	2125	18.44	2204	20.01	2279	21.57	2348	23.02	2414	24.45
6800	6453	1757	12.64	1841	13.92	1924	15.28	2002	16.60	2076	17.94	2160	19.57	2238	21.19	2313	22.80	2383	24.35	2448	25.83

SP		11"		12"		13"		14"		15"		16"		17"		18"		19"		20"	
OV	CFM	RPM	BHP	RPM	BHP	RPM	BHP	RPM	BHP	RPM	BHP	RPM	BHP	RPM	BHP	RPM	BHP	RPM	BHP	RPM	BHP
2000	1898	2001	7.76	2085	8.68	2166	9.63	2243	10.61	2318	11.61	2390	12.64	2461	13.67	2530	14.65	2597	15.64	2663	16.64
2200	2088	2013	8.10	2097	9.04	2177	10.02	2255	11.02	2329	12.05	2402	13.11	2472	14.18	2540	15.28	2606	16.41	2670	17.55
2400	2278	2024	8.44	2108	9.41	2189	10.42	2266	11.45	2341	12.50	2413	13.58	2483	14.69	2551	15.82	2617	16.97	2682	18.14
2600	2467	2035	8.81	2120	9.79	2200	10.82	2277	11.88	2352	12.96	2424	14.07	2494	15.20	2562	16.36	2629	17.54	2693	18.73
2800	2657	2044	9.24	2129	10.24	2211	11.26	2289	12.32	2364	13.43	2436	14.57	2506	15.73	2574	16.91	2640	18.11	2704	19.34
3000	2847	2053	9.68	2138	10.71	2220	11.76	2299	12.84	2375	13.93	2447	15.07	2517	16.26	2585	17.47	2651	18.70	2716	19.95
3200	3037	2062	10.12	2148	11.19	2229	12.28	2308	13.38	2384	14.51	2457	15.66	2528	16.83	2597	18.03	2663	19.29	2727	20.57
3400	3227	2072	10.57	2157	11.67	2238	12.80	2317	13.94	2393	15.10	2466	16.29	2537	17.49	2606	18.71	2674	19.94	2739	21.21
3600	3416	2091	11.28	2167	12.20	2248	13.33	2326	14.50	2402	15.70	2475	16.92	2546	18.16	2616	19.41	2683	20.68	2748	21.97
3800	3606	2112	12.05	2188	13.02	2261	13.99	2335	15.08	2411	16.31	2485	17.56	2556	18.83	2625	20.12	2692	21.43	2757	22.76
4000	3796	2133	12.84	2209	13.86	2282	14.88	2353	15.90	2421	16.93	2494	18.21	2565	19.52	2634	20.85	2701	22.19	2766	23.55
4200	3986	2154	13.66	2230	14.72	2303	15.80	2373	16.87	2441	17.94	2507	19.02	2574	20.22	2643	21.58	2710	22.95	2776	24.35
4400	4176	2175	14.50	2251	15.62	2324	16.74	2394	17.86	2462	18.98	2528	20.11	2592	21.24	2654	22.37	2719	23.73	2785	25.16
4600	4365	2197	15.34	2272	16.54	2345	17.71	2415	18.88	2483	20.06	2549	21.23	2612	22.40	2674	23.58	2734	24.76	2794	25.98
4800	4555	2221	16.16	2295	17.46	2366	18.71	2436	19.93	2504	21.16	2570	22.38	2633	23.60	2695	24.83	2755	26.06	2814	27.29
5000	4745	2246	17.00	2319	18.35	2389	19.71	2458	21.02	2525	22.29	2591	23.56	2654	24.83	2716	26.11	2776	27.39	2835	28.66
5200	4935	2270	17.88	2343	19.27	2413	20.67	2480	22.08	2547	23.45	2612	24.78	2675	26.10	2737	27.42	2797	28.75	2855	30.07
5400	5125	2295	18.78	2367	20.22	2437	21.67	2504	23.12	2569	24.59	2633	26.02	2696	27.40	2758	28.77	2818	30.14	2876	31.52
5600	5314	2320	19.72	2392	21.20	2462	22.69	2529	24.19	2594	25.70	2656	27.22	2718	28.73	2779	30.15	2839	31.58	2897	33.00
5800	5504	2345	20.68	2417	22.21	2486	23.75	2553	25.30	2618	26.85	2681	28.41	2742	29.98	2801	31.56	2860	33.04	2919	34.52
6000	5694	2377	21.88	2442	23.26	2511	24.84	2578	26.43	2642	28.03	2705	29.64	2766	31.26	2825	32.88	2882	34.51	2940	36.07
6200	5884	2410	23.16	2471	24.48	2536	25.97	2602	27.60	2667	29.25	2729	30.90	2790	32.56	2849	34.23	2907	35.91	2963	37.59
6400	6074	2443	24.49	2504	25.85	2564	27.21	2627	28.81	2692	30.50	2754	32.20	2814	33.91	2873	35.62	2931	37.34	2987	39.07
6600	6263	2477	25.87	2538	27.28	2597	28.69	2654	30.09	2716	31.79	2779	33.54	2839	35.29	2898	37.05	2955	38.81	3011	40.59
6800	6453	2511	27.30	2571	2																



# Model HF15

**Inlet Size: 15" Outside Diameter**

**Inlet Area: 1.192 Sq. Ft.**

**Max Safe Fan Speed: 2,500 RPM**

**Outlet Size: 12-3/4" x 14-3/4" Outside**

**Outlet Area: 1.253 Sq. Ft.**

**Wheel Diameter: 26"**

**Wheel Circumference: 6.81 Feet**

**Tip Speed (FPM): 6.81 x RPM**

SP		1"		2"		3"		4"		5"		6"		7"		8"		9"		10"	
OV	CFM	RPM	BHP	RPM	BHP	RPM	BHP	RPM	BHP	RPM	BHP	RPM	BHP	RPM	BHP	RPM	BHP	RPM	BHP	RPM	BHP
1000	1253	555	0.40	769	0.92	930	1.47	1066	2.06	1187	2.72	1297	3.42	1397	4.15	1491	4.93	1579	5.74	1662	6.58
1200	1504	566	0.47	778	1.05	940	1.67	1076	2.32	1196	3.01	1305	3.74	1406	4.53	1499	5.36	1587	6.22	1670	7.11
1400	1754	580	0.56	784	1.14	950	1.87	1087	2.59	1206	3.34	1315	4.12	1414	4.93	1508	5.80	1596	6.70	1679	7.65
1600	2005	599	0.66	793	1.26	956	2.01	1097	2.87	1217	3.68	1325	4.53	1425	5.40	1517	6.30	1604	7.23	1687	8.20
1800	2255	619	0.78	807	1.42	963	2.15	1103	3.05	1226	4.03	1335	4.94	1435	5.88	1527	6.84	1615	7.83	1697	8.84
2000	2506	647	0.94	822	1.60	974	2.36	1109	3.24	1233	4.25	1344	5.33	1445	6.37	1538	7.39	1625	8.44	1707	9.51
2200	2757	676	1.12	841	1.81	988	2.61	1117	3.46	1239	4.48	1351	5.60	1453	6.78	1548	7.95	1635	9.07	1717	10.20
2400	3007	707	1.33	860	2.03	1003	2.87	1131	3.78	1245	4.72	1357	5.88	1460	7.10	1555	8.37	1645	9.69	1728	10.90
2600	3258	742	1.59	882	2.29	1021	3.17	1145	4.12	1259	5.11	1363	6.16	1466	7.42	1561	8.73	1651	10.10	1736	11.51
2800	3508	778	1.88	911	2.61	1040	3.49	1160	4.47	1273	5.53	1376	6.60	1472	7.75	1568	9.10	1657	10.51	1742	11.96
3000	3759	814	2.20	940	2.96	1059	3.83	1178	4.88	1287	5.96	1390	7.10	1484	8.25	1574	9.48	1664	10.93	1749	12.42
3200	4010	850	2.57	970	3.35	1083	4.24	1197	5.30	1303	6.42	1404	7.61	1498	8.82	1586	10.06	1670	11.35	1755	12.89
3400	4260	888	2.97	1001	3.78	1111	4.72	1216	5.75	1322	6.93	1418	8.13	1512	9.41	1600	10.71	1683	12.02	1761	13.36
3600	4511	921	3.36	1036	4.28	1140	5.24	1237	6.24	1341	7.47	1436	8.73	1527	10.02	1614	11.38	1697	12.76	1775	14.15
3800	4761	954	3.78	1071	4.84	1170	5.80	1265	6.86	1360	8.03	1455	9.35	1543	10.68	1629	12.08	1711	13.51	1789	14.96
4000	5012	988	4.24	1107	5.44	1199	6.39	1294	7.52	1380	8.63	1474	10.01	1562	11.40	1644	12.80	1725	14.29	1803	15.80
4200	5263	1022	4.73	1143	6.09	1232	7.07	1323	8.22	1408	9.39	1493	10.69	1581	12.15	1662	13.61	1740	15.09	1817	16.66
4400	5513	1057	5.27	1180	6.79	1267	7.83	1353	8.97	1436	10.20	1514	11.42	1600	12.92	1681	14.45	1758	15.99	1832	17.55
4600	5764	1091	5.85	1217	7.56	1302	8.65	1382	9.76	1465	11.06	1542	12.34	1619	13.73	1700	15.32	1777	16.93	1850	18.53
4800	6014	1127	6.48	1254	8.37	1338	9.53	1414	10.64	1495	11.97	1571	13.31	1642	14.64	1719	16.23	1796	17.89	1868	19.57
5000	6265	1162	7.15	1297	9.14	1374	10.47	1449	11.64	1524	12.93	1600	14.34	1670	15.73	1739	17.16	1815	18.89	1887	20.63
5200	6516	1201	7.93	1320	9.95	1410	11.47	1484	12.70	1554	13.94	1629	15.41	1699	16.87	1765	18.31	1834	19.93	1906	21.73
5400	6766	1239	8.76	1354	10.80	1447	12.54	1519	13.83	1587	15.07	1658	16.54	1728	18.06	1793	19.57	1856	21.06	1926	22.87
5600	7017	1278	9.66	1388	11.71	1484	13.68	1555	15.02	1621	16.33	1688	17.73	1757	19.31	1822	20.88	1884	22.44	1945	24.04
5800	7267	1317	10.61	1422	12.68	1521	14.89	1591	16.29	1657	17.65	1718	18.98	1786	20.63	1851	22.26	1912	23.88	1971	25.48
6000	7518	1356	11.63	1456	13.70	1556	16.08	1627	17.63	1692	19.05	1753	20.44	1816	22.00	1880	23.70	1941	25.38	2000	27.05
6200	7769	1395	12.72	1490	14.78	1589	17.25	1664	19.05	1728	20.53	1788	21.98	1846	23.43	1909	25.20	1970	26.94	2028	28.68
6400	8019	1435	13.87	1525	15.92	1622	18.47	1701	20.55	1764	22.09	1823	23.59	1879	25.06	1939	26.76	1999	28.57	2057	30.37
6600	8270	1474	15.09	1560	17.12	1656	19.76	1738	22.13	1800	23.72	1858	25.28	1914	26.81	1969	28.40	2029	30.27	2086	32.13
6800	8520	1514	16.39	1595	18.39	1690	21.11	1775	23.79	1836	25.44	1894	27.06	1949	28.65	2002	30.21	2058	32.04	2115	33.97

SP		11"		12"		13"		14"		15"		16"		17"		18"		19"		20"	
OV	CFM	RPM	BHP	RPM	BHP	RPM	BHP	RPM	BHP	RPM	BHP	RPM	BHP	RPM	BHP	RPM	BHP	RPM	BHP	RPM	BHP
2000	2506	1785	10.61	1860	11.74	1932	12.88	2001	14.05	2068	15.23	2133	16.48	2196	17.76	2257	19.06	2317	20.39	2375	21.74
2200	2757	1796	11.36	1870	12.54	1942	13.75	2011	14.97	2078	16.22	2143	17.49	2205	18.77	2266	20.08	2325	21.44	2383	22.83
2400	3007	1806	12.13	1881	13.37	1952	14.63	2022	15.92	2088	17.23	2153	18.55	2215	19.90	2276	21.26	2335	22.64	2392	24.05
2600	3258	1816	12.91	1891	14.21	1963	15.54	2032	16.88	2098	18.25	2163	19.64	2225	21.04	2286	22.47	2345	23.91	2403	25.37
2800	3508	1823	13.46	1900	15.00	1973	16.46	2042	17.87	2109	19.29	2173	20.74	2236	22.21	2296	23.69	2355	25.20	2413	26.72
3000	3759	1829	13.96	1907	15.54	1981	17.16	2052	18.82	2119	20.36	2183	21.87	2246	23.39	2306	24.94	2365	26.50	2423	28.08
3200	4010	1836	14.47	1913	16.09	1987	17.75	2058	19.45	2127	21.20	2193	22.97	2256	24.60	2317	26.21	2376	27.83	2433	29.47
3400	4260	1842	14.98	1919	16.64	1993	18.35	2064	20.09	2133	21.87	2200	23.69	2264	25.55	2327	27.44	2386	29.18	2443	30.88
3600	4511	1850	15.55	1925	17.20	1999	18.95	2071	20.74	2139	22.56	2206	24.42	2270	26.32	2333	28.25	2394	30.21	2453	32.21
3800	4761	1863	16.43	1935	17.91	2006	19.56	2077	21.39	2146	23.25	2212	25.16	2276	27.09	2339	29.06	2400	31.07	2459	33.11
4000	5012	1877	17.33	1948	18.87	2017	20.43	2083	22.05	2152	23.96	2218	25.90	2283	27.88	2345	29.89	2406	31.94	2465	34.02
4200	5263	1892	18.25	1963	19.86	2031	21.47	2096	23.10	2160	24.74	2225	26.65	2289	28.67	2352	30.73	2412	32.81	2472	34.93
4400	5513	1906	19.20	1977	20.87	2045	22.54	2110	24.23	2173	25.94	2235	27.65	2295	29.47	2358	31.57	2419	33.70	2478	35.86
4600	5764	1920	20.17	1991	21.90	2059	23.64	2124	25.39	2187	27.16	2249	28.93	2308	30.72	2366	32.52	2425	34.59	2484	36.79
4800	6014	1938	21.24	2005	22.96	2073	24.76	2138	26.58	2202	28.40	2263	30.24	2322	32.09	2379	33.95	2436	35.82	2491	37.74
5000	6265	1956	22.38	2023	24.13	2087	25.91	2153	27.79	2216	29.68	2277	31.58	2336	33.49	2393	35.41	2449	37.34	2504	39.28
5200	6516	1975	23.54	2041	25.36	2105	27.18	2167	29.03	2230	30.98	2291	32.94	2350	34.92	2408	36.90	2463	38.89	2518	40.90
5400	6766	1994	24.74	2060	26.62	2123	28.51	2185	30.40	2244	32.31	2305	34.34	2364	36.37	2422	38.42	2478	40.47	2532	42.54
5600	7017	2013	25.98	2079	27.93	2142	29.88	2203	31.83	2262	33.79	2319	35.76	2379	37.86	2436	39.97	2492	42.09	2546	44.21
5800	7267	2033	27.26	2098	29.27	2161	31.28	2222	33.30	2281	35.33	2338	37.36	2393	39.39	2450	41.55	2506	43.73	2560	45.92
6000	7518	2056	28.71	2117	30.65	2180	32.73	2241	34.82	2300	36.91	2357	39.00	2412	41.10	2466	43.20	2520	45.41	2575	47.66
6200	7769	2084	30.40	2138	32.11	2200	34.22	2260	36.37	2319	38.53	2375	40.69	2431	42.85	2484	45.02	2536	47.19	2589	49.43
6400	8019	2112	32.15	2166	33.93	2219	35.75	2279	37.97	2338	40.19	2394	42.41	2449	44.64	2503	46.87	2555	49.11	2606	51.36
6600	8270	2141	33.98	2194	35.82	2246	37.64	2299	39.61	2357	41.90	2414	44.19	2468	46.48	2522					

# Model HF17

**Inlet Size: 17" Outside Diameter**

**Inlet Area: 1.536 Sq. Ft.**

**Max Safe Fan Speed: 2,200 RPM**

**Outlet Size: 14-1/2" x 16-1/2" Outside**

**Outlet Area: 1.602 Sq. Ft.**

**Wheel Diameter: 29-1/2"**

**Wheel Circumference: 7.72 Feet**

**Tip Speed (FPM): 7.72 x RPM**

SP		1"		2"		3"		4"		5"		6"		7"		8"		9"		10"	
OV	CFM	RPM	BHP	RPM	BHP	RPM	BHP	RPM	BHP	RPM	BHP	RPM	BHP	RPM	BHP	RPM	BHP	RPM	BHP	RPM	BHP
1000	1602	489	0.52	677	1.18	820	1.88	940	2.64	1046	3.49	1143	4.38	1231	5.33	1314	6.33	1391	7.36	1465	8.44
1200	1922	498	0.60	685	1.34	828	2.14	948	2.97	1054	3.85	1150	4.80	1239	5.81	1321	6.87	1399	7.98	1472	9.12
1400	2243	510	0.71	691	1.46	837	2.41	957	3.32	1063	4.28	1158	5.28	1246	6.32	1328	7.43	1406	8.60	1479	9.81
1600	2563	527	0.85	698	1.61	843	2.58	966	3.68	1072	4.72	1167	5.80	1255	6.92	1337	8.07	1414	9.26	1486	10.51
1800	2884	544	0.99	711	1.82	848	2.76	972	3.92	1081	5.16	1176	6.33	1264	7.53	1346	8.76	1422	10.03	1495	11.33
2000	3204	569	1.20	723	2.04	858	3.02	977	4.15	1086	5.45	1185	6.84	1273	8.15	1355	9.46	1431	10.81	1504	12.19
2200	3524	594	1.42	740	2.30	870	3.33	984	4.42	1092	5.75	1190	7.18	1280	8.70	1364	10.18	1440	11.61	1513	13.07
2400	3845	621	1.69	756	2.59	883	3.67	996	4.83	1097	6.05	1195	7.54	1286	9.10	1370	10.74	1449	12.43	1522	13.96
2600	4165	651	2.01	776	2.91	898	4.04	1008	5.26	1109	6.53	1201	7.90	1291	9.51	1376	11.20	1455	12.95	1530	14.76
2800	4486	682	2.38	800	3.32	915	4.45	1021	5.71	1121	7.06	1211	8.44	1297	9.93	1381	11.67	1460	13.48	1535	15.34
3000	4806	714	2.79	826	3.76	931	4.89	1037	6.22	1133	7.61	1224	9.07	1307	10.55	1387	12.15	1466	14.01	1541	15.93
3200	5126	746	3.25	852	4.25	952	5.39	1053	6.76	1147	8.19	1236	9.72	1319	11.28	1397	12.86	1471	14.55	1546	16.52
3400	5447	779	3.76	879	4.79	977	6.00	1070	7.33	1163	8.85	1249	10.39	1332	12.03	1409	13.69	1482	15.37	1552	17.12
3600	5767	808	4.26	909	5.43	1002	6.66	1087	7.94	1180	9.53	1264	11.14	1344	12.81	1421	14.55	1494	16.31	1563	18.09
3800	6088	837	4.79	940	6.13	1028	7.36	1112	8.72	1196	10.24	1280	11.93	1358	13.63	1434	15.43	1506	17.27	1575	19.13
4000	6408	867	5.37	971	6.89	1054	8.12	1137	9.56	1213	10.99	1297	12.77	1374	14.55	1446	16.34	1519	18.26	1588	20.19
4200	6728	897	6.00	1003	7.71	1081	8.96	1162	10.45	1237	11.95	1314	13.63	1391	15.50	1463	17.37	1531	19.27	1600	21.29
4400	7049	927	6.68	1035	8.60	1112	9.93	1188	11.40	1262	12.98	1331	14.53	1407	16.48	1479	18.44	1547	20.41	1613	22.42
4600	7369	957	7.41	1067	9.57	1143	10.97	1214	12.40	1287	14.06	1355	15.70	1424	17.51	1496	19.55	1563	21.60	1628	23.65
4800	7690	988	8.20	1100	10.60	1174	12.08	1241	13.50	1313	15.21	1380	16.93	1443	18.63	1513	20.70	1580	22.83	1644	24.97
5000	8010	1019	9.05	1129	11.60	1205	13.27	1272	14.76	1339	16.43	1405	18.23	1468	20.01	1529	21.88	1597	24.10	1661	26.32
5200	8330	1052	10.02	1158	12.62	1237	14.53	1302	16.10	1365	17.71	1431	19.59	1493	21.45	1551	23.29	1614	25.42	1677	27.72
5400	8651	1086	11.08	1188	13.70	1269	15.89	1333	17.53	1393	19.12	1457	21.02	1518	22.96	1576	24.89	1631	26.79	1694	29.17
5600	8971	1120	12.20	1217	14.85	1301	17.32	1365	19.04	1423	20.70	1483	22.53	1543	24.55	1601	26.55	1656	28.54	1711	30.66
5800	9292	1154	13.41	1247	16.07	1334	18.85	1396	20.64	1454	22.38	1509	24.10	1569	26.21	1626	28.30	1680	30.36	1732	32.42
6000	9612	1188	14.70	1277	17.36	1365	20.41	1428	22.34	1485	24.15	1538	25.92	1595	27.95	1652	30.12	1706	32.27	1757	34.40
6200	9932	1223	16.07	1307	18.73	1394	21.88	1460	24.13	1516	26.02	1569	27.86	1621	29.77	1677	32.02	1731	34.25	1782	36.46
6400	10253	1257	17.52	1337	20.17	1423	23.43	1492	26.02	1547	27.98	1600	29.90	1649	31.78	1703	34.00	1756	36.32	1807	38.61
6600	10573	1292	19.07	1368	21.69	1453	25.05	1524	28.02	1579	30.05	1631	32.05	1680	34.00	1729	36.07	1782	38.47	1833	40.85
6800	10894	1326	20.70	1399	23.29	1482	26.76	1557	30.12	1611	32.23	1662	34.30	1711	36.32	1757	38.32	1808	40.71	1858	43.17

SP		11"		12"		13"		14"		15"		16"		17"		18"		19"		20"	
OV	CFM	RPM	BHP	RPM	BHP	RPM	BHP	RPM	BHP	RPM	BHP	RPM	BHP	RPM	BHP	RPM	BHP	RPM	BHP	RPM	BHP
2000	3204	1573	13.60	1639	15.04	1702	16.50	1763	18.00	1822	19.53	1879	21.14	1935	22.78	1989	24.45	2041	26.16	2093	27.88
2200	3524	1582	14.55	1648	16.07	1711	17.61	1772	19.19	1831	20.78	1888	22.41	1943	24.06	1996	25.73	2049	27.49	2100	29.29
2400	3845	1591	15.53	1657	17.12	1720	18.74	1781	20.39	1840	22.07	1897	23.77	1952	25.50	2005	27.25	2057	29.02	2108	30.82
2600	4165	1600	16.52	1666	18.20	1729	19.90	1790	21.62	1849	23.38	1905	25.16	1961	26.96	2014	28.79	2066	30.64	2117	32.51
2800	4486	1606	17.26	1674	19.24	1738	21.07	1799	22.88	1858	24.71	1914	26.56	1969	28.45	2023	30.35	2075	32.28	2126	34.23
3000	4806	1612	17.90	1680	19.93	1745	22.02	1808	24.15	1867	26.06	1923	28.00	1978	29.96	2032	31.94	2084	33.94	2135	35.97
3200	5126	1617	18.55	1685	20.63	1751	22.77	1813	24.96	1874	27.19	1932	29.46	1987	31.49	2041	33.56	2093	35.64	2143	37.74
3400	5447	1623	19.21	1691	21.34	1756	23.53	1819	25.77	1879	28.06	1938	30.39	1995	32.77	2050	35.20	2102	37.36	2152	39.54
3600	5767	1629	19.88	1696	22.06	1762	24.30	1824	26.59	1885	28.93	1943	31.32	2000	33.76	2055	36.23	2109	38.76	2161	41.32
3800	6088	1641	21.00	1703	22.90	1767	25.08	1830	27.43	1890	29.82	1949	32.26	2006	34.75	2061	37.28	2114	39.85	2167	42.47
4000	6408	1653	22.15	1716	24.12	1776	26.11	1835	28.27	1896	30.72	1954	33.21	2011	35.75	2066	38.33	2120	40.96	2172	43.63
4200	6728	1665	23.33	1728	25.38	1788	27.45	1846	29.53	1902	31.63	1960	34.17	2017	36.76	2072	39.40	2125	42.08	2178	44.80
4400	7049	1678	24.53	1740	26.66	1800	28.81	1858	30.98	1914	33.16	1968	35.35	2022	37.78	2077	40.47	2131	43.21	2183	45.98
4600	7369	1690	25.77	1753	27.98	1813	30.21	1870	32.45	1926	34.71	1980	36.98	2032	39.27	2083	41.58	2136	44.35	2189	47.18
4800	7690	1705	27.11	1765	29.33	1825	31.64	1883	33.96	1938	36.30	1992	38.65	2044	41.02	2095	43.40	2145	45.80	2194	48.38
5000	8010	1721	28.55	1780	30.79	1838	33.10	1895	35.51	1951	37.92	2004	40.35	2057	42.80	2107	45.26	2157	47.73	2205	50.22
5200	8330	1738	30.04	1796	32.36	1852	34.68	1908	37.09	1963	39.58	2017	42.09	2069	44.62	2120	47.16	2169	49.71	2217	52.28
5400	8651	1755	31.56	1813	33.97	1868	36.38	1922	38.80	1976	41.28	2029	43.87	2081	46.48	2132	49.09	2181	51.73	2229	54.37
5600	8971	1771	33.14	1829	35.63	1885	38.12	1939	40.62	1991	43.13	2042	45.68	2094	48.37	2144	51.07	2194	53.78	2242	56.50
5800	9292	1788	34.76	1846	37.33	1902	39.91	1955	42.49	2007	45.08	2057	47.68	2106	50.30	2157	53.08	2206	55.87	2254	58.68
6000	9612	1807	36.52	1863	39.09	1918	41.75	1972	44.42	2023	47.09	2074	49.77	2122	52.45	2170	55.15	2219	58.01	2267	60.89
6200	9932	1831	38.66	1880	40.90	1935	43.64	1988	46.39	2040	49.15	2090	51.91	2139	54.68	2186	57.45	2232	60.23	2279	63.15
6400	10253	1856	40.89	1903	43.16	1952	45.59	2005	48.42	2057	51.26	2107	54.11	2155	56.96	2202	59.81	2248	62.68	2293	65.55
6600	10573	1881	43.21	1928	45.55	1974	47.88	2022	50.51	2074	53.43	2123	56.36	2172							



# Model HF19

**Inlet Size: 19" Outside Diameter**

**Inlet Area: 1.924 Sq. Ft.**

**Max Safe Fan Speed: 2,000 RPM**

**Outlet Size: 16" x 18-3/8" Outside**

**Outlet Area: 1.975 Sq. Ft.**

**Wheel Diameter: 32-1/2"**

**Wheel Circumference: 8.51 Feet**

**Tip Speed (FPM): 8.51 x RPM**

SP	1"		2"		3"		4"		5"		6"		7"		8"		9"		10"		
	OV	CFM	RPM	BHP	RPM	BHP	RPM	BHP	RPM	BHP	RPM	BHP	RPM	BHP	RPM	BHP	RPM	BHP	RPM	BHP	
1000	1975	433	0.56	592	1.23	722	2.11	831	3.12	927	4.24	1014	5.45	1095	6.76	1169	8.14	1239	9.60	1305	11.13
1200	2370	446	0.69	601	1.39	725	2.24	834	3.29	930	4.44	1017	5.70	1097	7.04	1172	8.47	1242	9.97	1308	11.54
1400	2765	460	0.84	611	1.58	733	2.46	837	3.46	933	4.65	1020	5.95	1100	7.33	1175	8.80	1245	10.34	1311	11.96
1600	3160	476	1.01	624	1.83	743	2.74	845	3.76	936	4.87	1023	6.20	1103	7.63	1178	9.13	1248	10.72	1314	12.37
1800	3555	495	1.20	638	2.11	753	3.04	855	4.13	945	5.28	1027	6.49	1106	7.92	1181	9.47	1251	11.09	1317	12.79
2000	3950	517	1.44	652	2.41	767	3.44	865	4.51	955	5.74	1037	7.02	1112	8.35	1184	9.81	1254	11.47	1320	13.21
2200	4345	539	1.70	669	2.74	781	3.86	878	5.00	966	6.22	1047	7.58	1122	8.98	1192	10.42	1258	11.90	1323	13.63
2400	4740	563	2.01	685	3.10	795	4.31	892	5.54	977	6.79	1057	8.15	1132	9.62	1202	11.14	1268	12.70	1330	14.30
2600	5135	588	2.36	705	3.52	811	4.80	905	6.12	991	7.46	1069	8.81	1142	10.29	1212	11.89	1278	13.52	1340	15.19
2800	5530	614	2.74	727	4.00	828	5.32	920	6.73	1005	8.16	1082	9.61	1154	11.06	1222	12.65	1288	14.37	1350	16.11
3000	5925	640	3.18	750	4.51	844	5.87	936	7.38	1019	8.90	1096	10.44	1167	11.99	1234	13.55	1298	15.23	1360	17.06
3200	6320	668	3.67	773	5.07	866	6.52	953	8.07	1034	9.68	1110	11.31	1181	12.96	1248	14.61	1310	16.27	1370	18.03
3400	6715	696	4.25	797	5.70	888	7.23	969	8.79	1051	10.51	1125	12.23	1195	13.97	1261	15.71	1324	17.47	1383	19.23
3600	7110	725	4.88	822	6.38	910	7.99	989	9.62	1067	11.37	1141	13.19	1209	15.01	1275	16.86	1337	18.71	1396	20.57
3800	7505	754	5.58	848	7.12	933	8.81	1011	10.53	1084	12.28	1157	14.20	1225	16.12	1289	18.05	1351	20.00	1410	21.95
4000	7900	783	6.34	874	7.93	956	9.68	1033	11.50	1103	13.30	1174	15.25	1241	17.27	1305	19.29	1365	21.33	1424	23.38
4200	8295	813	7.17	900	8.79	981	10.65	1056	12.53	1125	14.43	1190	16.35	1258	18.47	1321	20.59	1380	22.72	1438	24.86
4400	8690	843	8.08	927	9.73	1006	11.68	1078	13.63	1147	15.62	1211	17.61	1274	19.72	1337	21.94	1397	24.17	1453	26.39
4600	9085	873	9.07	955	10.80	1032	12.78	1101	14.79	1170	16.89	1232	18.96	1291	21.03	1354	23.35	1413	25.67	1469	27.99
4800	9480	903	10.14	983	11.96	1057	13.95	1126	16.06	1192	18.22	1255	20.39	1313	22.55	1370	24.81	1429	27.23	1485	29.65
5000	9875	934	11.29	1012	13.20	1084	15.21	1151	17.41	1215	19.62	1277	21.90	1335	24.15	1389	26.40	1446	28.84	1502	31.37
5200	10270	965	12.54	1041	14.54	1110	16.54	1177	18.84	1238	21.11	1299	23.47	1357	25.83	1411	28.17	1462	30.52	1518	33.14
5400	10665	996	13.88	1070	15.96	1136	17.95	1203	20.35	1263	22.72	1322	25.13	1379	27.59	1433	30.03	1484	32.45	1535	34.98
5600	11060	1028	15.32	1099	17.48	1165	19.56	1228	21.95	1289	24.42	1345	26.87	1402	29.42	1455	31.96	1506	34.49	1554	37.00
5800	11455	1060	16.86	1129	19.10	1193	21.27	1255	23.64	1314	26.20	1370	28.74	1424	31.35	1477	33.98	1528	36.61	1576	39.22
6000	11850	1091	18.50	1158	20.82	1221	23.08	1281	25.42	1340	28.08	1395	30.72	1447	33.36	1500	36.09	1550	38.81	1598	41.52
6200	12245	1123	20.25	1188	22.65	1250	25.00	1308	27.29	1366	30.06	1420	32.79	1471	35.50	1523	38.29	1572	41.11	1620	43.92
6400	12640	1155	22.11	1218	24.58	1279	27.03	1335	29.39	1392	32.13	1445	34.96	1496	37.76	1545	40.59	1595	43.51	1642	46.41
6600	13035	1187	24.08	1249	26.63	1308	29.17	1364	31.62	1418	34.30	1471	37.23	1521	40.13	1569	43.01	1618	46.00	1665	49.00
6800	13430	1219	26.17	1279	28.80	1338	31.43	1392	33.97	1444	36.58	1497	39.61	1547	42.61	1594	45.59	1641	48.59	1687	51.69

SP	11"		12"		13"		14"		15"		16"		17"		18"		19"		20"		
	OV	CFM	RPM	BHP	RPM	BHP	RPM	BHP	RPM	BHP	RPM	BHP	RPM	BHP	RPM	BHP	RPM	BHP	RPM	BHP	
2000	3950	1383	15.01	1443	16.88	1501	18.81	1557	20.80	1610	22.85	1662	24.95	1712	27.11	1761	29.32	1808	31.59	1855	33.90
2200	4345	1386	15.48	1446	17.39	1504	19.36	1560	21.39	1613	23.48	1665	25.62	1715	27.82	1764	30.07	1811	32.37	1858	34.73
2400	4740	1389	15.95	1449	17.90	1507	19.91	1563	21.98	1616	24.11	1668	26.29	1718	28.53	1767	30.82	1814	33.17	1861	35.56
2600	5135	1399	16.90	1455	18.64	1510	20.46	1566	22.57	1619	24.74	1671	26.97	1721	29.25	1770	31.58	1817	33.96	1864	36.40
2800	5530	1409	17.89	1465	19.71	1519	21.56	1571	23.43	1622	25.38	1674	27.65	1724	29.97	1773	32.34	1820	34.77	1867	37.24
3000	5925	1419	18.91	1475	20.80	1529	22.73	1581	24.68	1632	26.67	1680	28.68	1727	30.72	1776	33.11	1823	35.57	1870	38.09
3200	6320	1429	19.96	1485	21.93	1539	23.93	1591	25.96	1642	28.01	1690	30.10	1737	32.22	1783	34.36	1828	36.53	1873	38.94
3400	6715	1439	21.03	1495	23.08	1549	25.15	1601	27.26	1652	29.39	1700	31.56	1747	33.75	1793	35.97	1838	38.21	1881	40.48
3600	7110	1452	22.44	1506	24.31	1560	26.41	1612	28.59	1662	30.80	1710	33.04	1757	35.31	1803	37.60	1848	39.92	1891	42.27
3800	7505	1466	23.91	1520	25.88	1571	27.86	1622	29.95	1672	32.24	1720	34.56	1767	36.90	1813	39.27	1858	41.67	1901	44.09
4000	7900	1480	25.44	1533	27.50	1585	29.57	1634	31.65	1682	33.73	1731	36.11	1778	38.53	1823	40.98	1868	43.45	1911	45.95
4200	8295	1494	27.01	1547	29.17	1599	31.34	1648	33.51	1696	35.69	1742	37.87	1788	40.19	1833	42.71	1878	45.26	1921	47.83
4400	8690	1508	28.64	1561	30.89	1612	33.16	1662	35.42	1709	37.70	1756	39.98	1801	42.26	1844	44.55	1888	47.11	1931	49.76
4600	9085	1523	30.32	1575	32.67	1626	35.03	1676	37.39	1723	39.76	1769	42.14	1814	44.52	1858	46.90	1900	49.29	1941	51.72
4800	9480	1539	32.08	1590	34.50	1640	36.95	1689	39.42	1737	41.88	1783	44.35	1828	46.83	1871	49.31	1914	51.80	1955	54.29
5000	9875	1555	33.89	1606	36.42	1655	38.95	1703	41.50	1751	44.06	1797	46.63	1842	49.20	1885	51.78	1927	54.36	1968	56.95
5200	10270	1571	35.76	1622	38.39	1671	41.02	1719	43.65	1765	46.30	1811	48.96	1855	51.64	1899	54.31	1941	56.99	1982	59.67
5400	10665	1588	37.70	1639	40.43	1688	43.15	1735	45.88	1780	48.62	1825	51.36	1869	54.13	1913	56.90	1955	59.68	1996	62.46
5600	11060	1604	39.71	1655	42.53	1704	45.36	1751	48.18	1796	51.01	1841	53.85	1883	56.69	1927	59.56	1969	62.43	2010	65.31
5800	11455	1622	41.82	1672	44.70	1720	47.62	1767	50.55	1813	53.48	1857	56.41	1899	59.34	1941	62.28	1983	65.25	2024	68.23
6000	11850	1644	44.22	1688	46.94	1737	49.96	1784	52.99	1829	56.02	1873	59.05	1916	62.08	1957	65.11	1997	68.15	2038	71.21
6200	12245	1666	46.71	1710	49.50	1754	52.37	1800	55.50	1845	58.63	1889	61.75	1932	64.88	1973	68.02	2014	71.15	2053	74.29
6400	12640	1688	49.30	1731	52.18	1774	55.06	1817	58.08	1862	61.31	1906	64.54	1948	67.77	1989	71.00	2030	74.23	2069	77.47
6600	13035	1710	51.99	1753	54.97	1795	57.94	1836	60.90	1879	64.07	1922	67.40	1965	70.73	2006	74.06				



Inlet Size: 21" Outside Diameter

Inlet Area: 2.356 Sq. Ft.

Max Safe Fan Speed: 1,790 RPM

# Model HF21

Outlet Size: 17-11/16" x 20-3/8" Outside

Outlet Area: 2.429 Sq. Ft.

Wheel Diameter: 36-1/4"

Wheel Circumference: 9.49 Feet

Tip Speed (FPM): 9.49 x RPM

SP		1"		2"		3"		4"		5"		6"		7"		8"		9"		10"	
OV	CFM	RPM	BHP	RPM	BHP	RPM	BHP	RPM	BHP	RPM	BHP	RPM	BHP	RPM	BHP	RPM	BHP	RPM	BHP	RPM	BHP
1000	2429	387	0.73	534	1.67	647	2.80	741	4.08	826	5.36	903	6.70	974	8.10	1039	9.57	1101	11.09	1160	12.67
1200	2915	398	0.89	541	1.85	654	3.03	748	4.38	832	5.85	907	7.42	978	8.94	1044	10.53	1105	12.17	1164	13.86
1400	3401	411	1.09	546	2.05	660	3.29	755	4.69	839	6.24	914	7.89	983	9.64	1048	11.49	1110	13.25	1168	15.06
1600	3886	426	1.28	556	2.35	666	3.60	762	5.04	846	6.63	921	8.35	990	10.18	1055	12.10	1115	14.10	1173	16.19
1800	4372	441	1.51	569	2.72	671	3.90	768	5.44	852	7.07	928	8.83	997	10.72	1062	12.71	1122	14.79	1180	16.95
2000	4858	462	1.81	582	3.11	684	4.42	773	5.85	858	7.57	934	9.37	1004	11.28	1069	13.34	1129	15.49	1187	17.72
2200	5344	483	2.16	597	3.50	697	4.98	783	6.42	863	8.08	940	9.98	1010	11.95	1076	14.00	1136	16.20	1194	18.50
2400	5830	504	2.54	612	3.92	710	5.57	795	7.14	871	8.71	946	10.59	1016	12.66	1081	14.79	1143	17.00	1201	19.31
2600	6315	524	2.96	630	4.42	724	6.14	808	7.89	884	9.59	952	11.30	1021	13.38	1087	15.60	1148	17.90	1207	20.26
2800	6801	546	3.42	650	5.03	739	6.75	822	8.68	897	10.52	965	12.35	1028	14.18	1093	16.43	1154	18.81	1212	21.26
3000	7287	567	3.93	671	5.70	755	7.40	836	9.45	910	11.49	978	13.45	1041	15.41	1100	17.37	1160	19.75	1218	22.28
3200	7773	590	4.52	692	6.43	773	8.19	851	10.26	924	12.46	991	14.60	1054	16.68	1112	18.77	1167	20.87	1224	23.32
3400	8259	615	5.21	713	7.21	793	9.10	866	11.11	938	13.43	1004	15.79	1067	18.01	1125	20.23	1180	22.45	1232	24.68
3600	8744	641	5.97	734	8.03	814	10.09	883	12.06	953	14.45	1019	16.93	1080	19.39	1138	21.73	1193	24.08	1245	26.43
3800	9230	666	6.80	755	8.91	835	11.14	903	13.23	969	15.52	1034	18.11	1094	20.73	1151	23.30	1206	25.78	1258	28.25
4000	9716	692	7.72	776	9.87	856	12.27	923	14.49	984	16.67	1049	19.36	1109	22.09	1165	24.86	1219	27.53	1271	30.14
4200	10202	718	8.72	798	10.89	877	13.45	944	15.82	1004	18.13	1064	20.65	1124	23.51	1179	26.39	1232	29.31	1284	32.08
4400	10688	745	9.81	819	12.00	898	14.69	965	17.24	1025	19.67	1080	22.07	1139	24.99	1194	27.99	1247	31.01	1297	34.07
4600	11173	771	10.99	844	13.28	919	16.01	986	18.75	1046	21.30	1100	23.82	1154	26.52	1209	29.64	1262	32.79	1312	35.96
4800	11659	798	12.26	869	14.67	940	17.41	1007	20.32	1066	23.02	1121	25.67	1171	28.29	1225	31.36	1277	34.62	1326	37.91
5000	12145	825	13.65	894	16.17	961	18.89	1028	21.94	1087	24.84	1141	27.61	1192	30.35	1240	33.15	1292	36.53	1341	39.94
5200	12631	853	15.16	920	17.77	983	20.47	1049	23.65	1109	26.76	1162	29.65	1212	32.51	1259	35.35	1307	38.51	1357	42.03
5400	13117	880	16.77	945	19.47	1005	22.13	1070	25.45	1130	28.73	1183	31.80	1233	34.78	1279	37.74	1324	40.69	1372	44.20
5600	13602	908	18.50	971	21.30	1029	24.06	1091	27.35	1150	30.76	1204	34.06	1253	37.16	1300	40.24	1344	43.31	1387	46.44
5800	14088	936	20.35	997	23.23	1054	26.11	1113	29.36	1171	32.90	1226	36.40	1274	39.65	1321	42.86	1364	46.04	1406	49.21
6000	14574	964	22.32	1024	25.30	1080	28.29	1134	31.46	1192	35.14	1246	38.78	1296	42.26	1341	45.59	1385	48.89	1427	52.18
6200	15060	992	24.42	1050	27.48	1105	30.59	1156	33.67	1214	37.49	1267	41.26	1317	44.99	1362	48.44	1406	51.87	1447	55.28
6400	15546	1020	26.65	1076	29.80	1130	33.03	1180	36.17	1235	39.95	1288	43.86	1338	47.73	1384	51.42	1427	54.97	1468	58.50
6600	16031	1048	29.03	1103	32.25	1156	35.60	1205	38.85	1257	42.53	1309	46.57	1358	50.58	1405	54.52	1448	58.20	1488	61.85
6800	16517	1077	31.54	1130	34.84	1182	38.30	1230	41.67	1278	45.22	1330	49.40	1379	53.54	1426	57.65	1469	61.56	1509	65.33

SP		11"		12"		13"		14"		15"		16"		17"		18"		19"		20"	
OV	CFM	RPM	BHP	RPM	BHP	RPM	BHP	RPM	BHP	RPM	BHP	RPM	BHP	RPM	BHP	RPM	BHP	RPM	BHP	RPM	BHP
2000	4858	1241	20.02	1293	22.41	1343	24.86	1391	27.38	1438	29.97	1483	32.63	1527	35.19	1570	37.71	1612	40.26	1652	42.85
2200	5344	1248	20.88	1300	23.33	1350	25.86	1398	28.45	1445	31.11	1490	33.83	1533	36.62	1575	39.46	1616	42.37	1656	45.29
2400	5830	1255	21.75	1307	24.28	1357	26.87	1405	29.53	1452	32.26	1497	35.05	1540	37.91	1582	40.82	1623	43.80	1663	46.83
2600	6315	1262	22.68	1314	25.24	1364	27.90	1412	30.63	1459	33.43	1503	36.29	1547	39.22	1589	42.20	1630	45.25	1670	48.35
2800	6801	1268	23.77	1320	26.34	1371	28.97	1419	31.75	1466	34.62	1511	37.56	1554	40.55	1596	43.61	1637	46.72	1677	49.89
3000	7287	1273	24.88	1326	27.54	1377	30.26	1426	33.02	1473	35.84	1518	38.84	1561	41.91	1603	45.03	1644	48.21	1684	51.45
3200	7773	1279	26.01	1332	28.76	1382	31.56	1431	34.42	1478	37.33	1524	40.29	1568	43.30	1610	46.48	1651	49.73	1691	53.04
3400	8259	1284	27.16	1337	30.00	1388	32.89	1437	35.84	1484	38.84	1529	41.89	1574	44.98	1616	48.13	1658	51.32	1698	54.65
3600	8744	1295	28.79	1343	31.26	1394	34.24	1442	37.28	1489	40.37	1535	43.50	1579	46.69	1622	49.93	1664	53.20	1704	56.53
3800	9230	1307	30.74	1355	33.23	1400	35.72	1448	38.74	1495	41.92	1541	45.14	1585	48.42	1628	51.74	1669	55.11	1710	58.53
4000	9716	1320	32.74	1367	35.36	1413	37.98	1457	40.60	1501	43.49	1546	46.81	1590	50.17	1633	53.59	1675	57.04	1716	60.55
4200	10202	1333	34.82	1380	37.56	1426	40.30	1469	43.05	1512	45.80	1552	48.56	1596	51.95	1639	55.45	1681	59.00	1721	62.59
4400	10688	1346	36.96	1393	39.82	1438	42.69	1482	45.56	1524	48.44	1565	51.32	1605	54.21	1645	57.34	1686	60.98	1727	64.66
4600	11173	1359	39.16	1406	42.16	1451	45.16	1495	48.16	1537	51.16	1578	54.16	1617	57.18	1656	60.19	1693	63.22	1732	66.75
4800	11659	1374	41.23	1419	44.57	1464	47.70	1508	50.82	1550	53.95	1591	57.08	1630	60.22	1668	63.36	1706	66.50	1742	69.65
5000	12145	1389	43.37	1434	46.82	1477	50.30	1521	53.57	1563	56.82	1603	60.08	1643	63.34	1681	66.61	1718	69.87	1755	73.15
5200	12631	1404	45.58	1449	49.15	1492	52.74	1534	56.36	1576	59.77	1616	63.16	1656	66.55	1694	69.94	1731	73.33	1768	76.73
5400	13117	1419	47.86	1464	51.55	1507	55.26	1549	58.99	1589	62.75	1629	66.32	1669	69.84	1707	73.35	1744	76.87	1780	80.39
5600	13602	1434	50.22	1479	54.03	1522	57.85	1564	61.70	1604	65.57	1643	69.47	1682	73.21	1720	76.86	1757	80.50	1793	84.15
5800	14088	1449	52.66	1494	56.59	1537	60.53	1579	64.50	1619	68.48	1658	72.49	1696	76.52	1733	80.45	1770	84.22	1806	88.00
6000	14574	1467	55.45	1509	59.22	1552	63.29	1594	67.37	1634	71.47	1673	75.60	1710	79.74	1747	83.91	1783	88.04	1819	91.94
6200	15060	1487	58.66	1525	62.04	1567	66.13	1609	70.33	1649	74.55	1687	78.79	1725	83.05	1762	87.33	1798	91.63	1832	95.95
6400	15546	1507	62.01	1545	65.50	1583	69.05	1624	73.38	1664	77.72	1702	82.07	1740	86.45	1777	90.85	1812	95.26	1847	99.69
6600	16031	1528	65.48	1566	69.09	1602	72.69	1639	76.51	1679	80.97	1718	85.45	1755	89.94	1792	94.45	1827	98.98	1862	103.5</

# Model HF23

**Inlet Size: 23" Outside Diameter**

**Inlet Area: 2.831 Sq. Ft.**

**Max Safe Fan Speed: 1,635 RPM**

**Outlet Size: 19-9/16" x 22-7/16" Outside**

**Outlet Area: 2.940 Sq. Ft.**

**Wheel Diameter: 39-3/4"**

**Wheel Circumference: 10.41 Feet**

**Tip Speed (FPM): 10.41 x RPM**

SP	1"		2"		3"		4"		5"		6"		7"		8"		9"		10"		
	OV	CFM	RPM	BHP	RPM	BHP	RPM	BHP	RPM	BHP	RPM	BHP	RPM	BHP	RPM	BHP	RPM	BHP	RPM	BHP	
1000	2940	363	0.95	503	2.17	609	3.44	698	4.83	777	6.36	848	8.00	914	9.73	975	11.54	1033	13.43	1087	15.39
1200	3528	370	1.11	509	2.45	615	3.92	704	5.44	783	7.04	854	8.77	920	10.62	981	12.55	1038	14.55	1093	16.64
1400	4116	380	1.31	513	2.67	622	4.39	711	6.08	789	7.83	860	9.66	925	11.56	986	13.57	1044	15.70	1098	17.91
1600	4704	392	1.56	519	2.95	626	4.71	717	6.73	796	8.64	867	10.61	932	12.65	993	14.76	1050	16.94	1104	19.20
1800	5292	405	1.84	528	3.34	630	5.04	722	7.15	802	9.43	874	11.59	939	13.77	999	16.03	1056	18.34	1110	20.72
2000	5880	424	2.21	538	3.76	638	5.54	726	7.58	806	9.96	880	12.48	945	14.93	1006	17.32	1063	19.78	1117	22.30
2200	6468	443	2.64	550	4.24	647	6.12	731	8.11	811	10.50	884	13.12	951	15.88	1013	18.65	1070	21.25	1124	23.91
2400	7056	463	3.14	563	4.77	656	6.74	740	8.87	815	11.06	888	13.77	955	16.62	1017	19.60	1076	22.70	1130	25.56
2600	7644	486	3.74	578	5.39	668	7.44	750	9.67	824	12.00	892	14.43	959	17.38	1022	20.46	1080	23.65	1136	26.95
2800	8232	510	4.43	597	6.14	681	8.20	759	10.50	833	12.97	900	15.49	963	18.15	1026	21.33	1084	24.62	1140	28.02
3000	8820	534	5.20	616	6.97	693	9.00	771	11.45	843	13.98	910	16.65	971	19.36	1030	22.21	1088	25.60	1144	29.09
3200	9408	558	6.06	635	7.88	709	9.98	784	12.46	853	15.08	919	17.85	981	20.71	1038	23.60	1093	26.59	1148	30.18
3400	9996	582	7.01	656	8.90	728	11.11	796	13.51	865	16.29	928	19.09	990	22.10	1047	25.14	1101	28.22	1153	31.33
3600	10584	604	7.92	679	10.10	747	12.33	810	14.68	878	17.55	940	20.50	999	23.53	1057	26.72	1111	29.94	1162	33.20
3800	11172	626	8.91	702	11.40	767	13.65	829	16.14	890	18.87	953	21.97	1010	25.09	1066	28.35	1120	31.72	1171	35.12
4000	11760	648	9.99	726	12.82	786	15.05	848	17.70	904	20.30	965	23.51	1022	26.78	1076	30.06	1129	33.54	1180	37.09
4200	12348	670	11.16	750	14.36	808	16.66	867	19.36	922	22.11	978	25.11	1035	28.54	1088	31.97	1139	35.43	1190	39.12
4400	12936	693	12.43	774	16.03	831	18.46	886	21.12	941	24.02	992	26.88	1047	30.36	1101	33.95	1151	37.56	1199	41.20
4600	13524	716	13.80	798	17.82	854	20.40	906	22.99	960	26.04	1010	29.05	1060	32.26	1113	36.00	1163	39.76	1211	43.53
4800	14112	739	15.28	822	19.76	877	22.47	927	25.08	979	28.18	1029	31.34	1076	34.46	1126	38.13	1176	42.04	1223	45.96
5000	14700	763	16.89	844	21.55	901	24.69	950	27.44	999	30.44	1048	33.75	1094	37.02	1138	40.33	1188	44.39	1236	48.47
5200	15288	788	18.72	866	23.45	925	27.06	973	29.94	1018	32.82	1067	36.28	1113	39.70	1156	43.09	1201	46.83	1248	51.06
5400	15876	813	20.69	888	25.47	949	29.59	996	32.60	1040	35.53	1087	38.95	1132	42.52	1175	46.05	1216	49.55	1261	53.74
5600	16464	839	22.80	910	27.62	973	32.27	1020	35.43	1063	38.49	1106	41.75	1151	45.47	1194	49.15	1234	52.80	1273	56.50
5800	17052	864	25.06	932	29.89	998	35.13	1043	38.42	1086	41.62	1126	44.75	1170	48.56	1213	52.39	1253	56.19	1291	59.97
6000	17640	890	27.47	955	32.31	1020	37.90	1067	41.59	1109	44.93	1149	48.19	1190	51.80	1232	55.78	1272	59.73	1310	63.65
6200	18228	916	30.04	978	34.86	1042	40.65	1091	44.94	1133	48.41	1172	51.81	1210	55.18	1251	59.32	1291	63.42	1329	67.49
6400	18816	942	32.76	1000	37.55	1064	43.54	1116	48.47	1156	52.08	1195	55.61	1232	59.07	1271	63.02	1310	67.27	1348	71.48
6600	19404	968	35.66	1023	40.39	1086	46.58	1140	52.20	1180	55.95	1218	59.62	1255	63.21	1290	66.87	1329	71.27	1367	75.64
6800	19992	994	38.72	1046	43.39	1108	49.77	1164	56.09	1204	60.01	1242	63.82	1278	67.55	1312	71.21	1349	75.44	1386	79.96

SP	11"		12"		13"		14"		15"		16"		17"		18"		19"		20"		
	OV	CFM	RPM	BHP	RPM	BHP	RPM	BHP	RPM	BHP	RPM	BHP	RPM	BHP	RPM	BHP	RPM	BHP	RPM	BHP	
2000	5880	1168	24.87	1217	27.50	1264	30.18	1309	32.91	1353	35.66	1395	38.60	1437	41.60	1477	44.65	1516	47.75	1554	50.90
2200	6468	1175	26.63	1224	29.40	1271	32.22	1316	35.09	1360	38.01	1402	40.98	1443	43.99	1482	47.04	1521	50.21	1559	53.48
2400	7056	1181	28.42	1230	31.34	1277	34.30	1323	37.31	1366	40.37	1408	43.48	1449	46.63	1489	49.83	1528	53.07	1565	56.34
2600	7644	1188	30.26	1237	33.31	1284	36.42	1329	39.58	1373	42.78	1415	46.03	1456	49.32	1496	52.66	1534	56.04	1572	59.46
2800	8232	1193	31.52	1243	35.13	1291	38.58	1336	41.88	1380	45.23	1422	48.62	1463	52.06	1502	55.54	1541	59.06	1578	62.62
3000	8820	1197	32.70	1247	36.40	1296	40.19	1342	44.08	1386	47.72	1428	51.26	1469	54.84	1509	58.46	1548	62.13	1585	65.83
3200	9408	1201	33.88	1251	37.68	1300	41.58	1346	45.56	1391	49.64	1435	53.80	1476	57.67	1516	61.44	1554	65.24	1592	69.09
3400	9996	1205	35.09	1256	38.99	1304	42.98	1351	47.06	1395	51.23	1439	55.49	1481	59.83	1522	64.25	1561	68.41	1599	72.40
3600	10584	1210	36.49	1260	40.30	1308	44.39	1355	48.58	1400	52.84	1443	57.20	1485	61.64	1526	66.15	1566	70.75	1605	75.42
3800	11172	1220	38.55	1266	42.02	1312	45.83	1359	50.11	1404	54.47	1447	58.93	1489	63.46	1530	68.08	1570	72.77	1609	77.54
4000	11760	1229	40.67	1275	44.28	1320	47.93	1363	51.65	1408	56.12	1451	60.67	1493	65.30	1534	70.02	1574	74.81	1613	79.67
4200	12348	1238	42.84	1284	46.60	1329	50.39	1372	54.21	1413	58.06	1455	62.43	1498	67.16	1538	71.97	1578	76.86	1617	81.83
4400	12936	1247	45.07	1294	48.97	1338	52.91	1381	56.87	1422	60.86	1462	64.88	1502	69.04	1543	73.95	1582	78.94	1621	84.00
4600	13524	1257	47.36	1303	51.41	1347	55.49	1390	59.59	1432	63.73	1472	67.89	1510	72.08	1548	76.30	1587	81.04	1625	86.20
4800	14112	1269	49.90	1312	53.90	1357	58.13	1400	62.38	1441	66.66	1481	70.97	1520	75.30	1557	79.66	1594	84.05	1630	88.46
5000	14700	1281	52.56	1324	56.66	1366	60.83	1409	65.23	1450	69.66	1490	74.11	1529	78.59	1566	83.10	1603	87.63	1639	92.18
5200	15288	1293	55.30	1336	59.56	1378	63.83	1418	68.15	1459	72.73	1499	77.33	1538	81.95	1576	86.60	1612	91.27	1648	95.97
5400	15876	1306	58.13	1349	62.54	1390	66.96	1430	71.39	1469	75.86	1509	80.61	1547	85.38	1585	90.17	1622	94.99	1657	99.84
5600	16464	1318	61.05	1361	65.61	1403	70.18	1442	74.77	1481	79.36	1518	83.97	1557	88.87	1594	93.82	1631	98.78	1666	103.8
5800	17052	1331	64.05	1374	68.77	1415	73.50	1455	78.23	1493	82.98	1531	87.74	1567	92.52	1604	97.54	1640	102.7	1676	107.8
6000	17640	1347	67.55	1386	72.03	1428	76.91	1467	81.80	1506	86.70	1543	91.61	1579	96.53	1614	101.5	1650	106.6	1685	111.9
6200	18228	1365	71.53	1400	75.55	1440	80.41	1480	85.46	1518	90.51	1555	95.57	1591	100.6	1626	105.7	1661	110.8	1694	116.0
6400	18816	1384	75.67	1419	79.84	1453	84.01	1492	89.22	1531	94.42	1568	99.64	1604	104.9	1639	110.1	1673	115.4	1706	120.6
6600	19404	1403	79.98	1438	84.29	1471	88.58	1505	93.08	1543	98.44	1580	103.8	1616	109.2	1651	114.6	1685			



Inlet Size: 26" Outside Diameter

Inlet Area: 3.625 Sq. Ft.

Max Safe Fan Speed: 1,440 RPM

# Model HF26

Outlet Size: 22" x 25-5/16" Outside

Outlet Area: 3.746 Sq. Ft.

Wheel Diameter: 45-1/8"

Wheel Circumference: 11.81 Feet

Tip Speed (FPM): 11.81 x RPM

SP		1"		2"		3"		4"		5"		6"		7"		8"		9"		10"	
OV	CFM	RPM	BHP	RPM	BHP	RPM	BHP	RPM	BHP	RPM	BHP	RPM	BHP	RPM	BHP	RPM	BHP	RPM	BHP	RPM	BHP
1000	3746	319	1.21	443	2.77	536	4.40	614	6.18	684	8.15	747	10.25	805	12.47	859	14.80	910	17.23	957	19.75
1200	4495	326	1.41	448	3.14	542	5.01	620	6.95	689	9.01	752	11.23	810	13.60	864	16.08	914	18.66	962	21.33
1400	5244	334	1.67	451	3.41	547	5.63	626	7.77	695	10.01	757	12.35	815	14.79	868	17.39	919	20.12	967	22.94
1600	5994	344	1.98	457	3.76	551	6.03	632	8.61	701	11.03	763	13.56	820	16.18	874	18.88	924	21.67	972	24.59
1800	6743	355	2.32	465	4.25	554	6.45	635	9.16	706	12.08	769	14.80	826	17.60	880	20.49	930	23.45	977	26.50
2000	7492	372	2.79	473	4.78	561	7.05	639	9.71	710	12.76	774	15.99	832	19.06	886	22.13	936	25.28	983	28.51
2200	8241	388	3.33	483	5.39	569	7.79	643	10.33	714	13.44	778	16.81	837	20.34	891	23.82	942	27.15	989	30.56
2400	8990	406	3.94	494	6.05	577	8.57	651	11.30	717	14.14	781	17.63	841	21.29	896	25.11	947	29.06	995	32.65
2600	9740	425	4.70	507	6.80	587	9.46	659	12.30	725	15.28	785	18.47	844	22.26	899	26.20	951	30.30	1000	34.53
2800	10489	446	5.56	523	7.76	598	10.41	667	13.35	733	16.51	792	19.74	848	23.23	903	27.30	955	31.52	1004	35.89
3000	11238	466	6.52	540	8.80	609	11.42	678	14.54	741	17.80	800	21.20	854	24.67	907	28.43	958	32.77	1007	37.26
3200	11987	487	7.60	557	9.93	622	12.61	688	15.81	749	19.16	808	22.72	862	26.37	913	30.07	962	34.03	1011	38.64
3400	12736	509	8.79	574	11.19	638	14.03	699	17.15	760	20.68	816	24.29	870	28.13	921	32.01	969	35.94	1014	40.05
3600	13486	528	9.96	594	12.69	655	15.57	711	18.55	771	22.28	826	26.04	879	29.94	929	34.01	977	38.13	1022	42.29
3800	14235	547	11.20	614	14.32	672	17.21	727	20.39	782	23.95	837	27.90	888	31.87	937	36.07	985	40.38	1030	44.72
4000	14984	566	12.55	635	16.09	689	18.98	743	22.34	793	25.70	848	29.84	898	34.01	945	38.20	993	42.69	1038	47.22
4200	15733	586	14.01	655	18.02	707	20.95	760	24.42	809	27.92	859	31.87	909	36.23	956	40.61	1001	45.06	1046	49.78
4400	16482	606	15.60	676	20.10	727	23.20	776	26.64	825	30.33	870	33.97	920	38.53	967	43.11	1011	47.71	1054	52.42
4600	17232	625	17.31	697	22.35	747	25.62	793	28.99	841	32.87	886	36.69	931	40.93	978	45.70	1022	50.49	1064	55.30
4800	17981	645	19.16	719	24.77	767	28.22	811	31.53	858	35.55	902	39.57	943	43.54	989	48.38	1033	53.37	1075	58.37
5000	18730	666	21.14	738	27.10	788	30.99	831	34.48	875	38.39	918	42.60	959	46.75	1000	51.16	1044	56.34	1085	61.54
5200	19479	687	23.41	757	29.48	808	33.95	851	37.62	892	41.38	935	45.78	976	50.13	1014	54.44	1055	59.42	1096	64.81
5400	20228	709	25.87	776	32.01	829	37.11	871	40.95	910	44.67	952	49.13	992	53.67	1030	58.16	1066	62.62	1107	68.19
5600	20978	732	28.51	795	34.70	850	40.47	892	44.48	930	48.38	969	52.64	1009	57.37	1046	62.06	1082	66.70	1118	71.67
5800	21727	754	31.32	815	37.54	872	44.04	912	48.22	950	52.29	986	56.33	1025	61.26	1063	66.13	1098	70.96	1132	75.76
6000	22476	776	34.33	834	40.56	892	47.68	933	52.19	970	56.43	1005	60.57	1042	65.32	1079	70.39	1115	75.41	1148	80.40
6200	23225	799	37.53	854	43.75	911	51.12	954	56.37	991	60.79	1025	65.10	1059	69.57	1096	74.83	1131	80.04	1165	85.22
6400	23974	821	40.93	874	47.12	930	54.74	975	60.79	1011	65.38	1045	69.87	1078	74.26	1113	79.46	1148	84.87	1181	90.24
6600	24724	844	44.53	894	50.67	949	58.54	996	65.45	1032	70.22	1066	74.87	1098	79.44	1130	84.30	1165	89.90	1198	95.46
6800	25473	867	48.36	914	54.41	969	62.53	1017	70.35	1053	75.30	1086	80.13	1118	84.87	1148	89.53	1182	95.13	1215	100.9

SP		11"		12"		13"		14"		15"		16"		17"		18"		19"		20"	
OV	CFM	RPM	BHP	RPM	BHP	RPM	BHP	RPM	BHP	RPM	BHP	RPM	BHP	RPM	BHP	RPM	BHP	RPM	BHP	RPM	BHP
2000	7492	1028	31.80	1071	35.17	1113	38.60	1153	42.10	1191	45.67	1229	49.45	1265	53.29	1300	57.20	1335	61.18	1368	65.22
2200	8241	1034	34.03	1077	37.58	1119	41.20	1158	44.87	1197	48.61	1234	52.41	1270	56.27	1305	60.18	1339	64.31	1373	68.51
2400	8990	1040	36.31	1083	40.04	1124	43.84	1164	47.70	1203	51.62	1240	55.59	1276	59.63	1311	63.72	1345	67.87	1378	72.07
2600	9740	1046	38.64	1089	42.55	1130	46.53	1170	50.57	1208	54.67	1246	58.83	1282	63.05	1317	67.32	1351	71.65	1384	76.03
2800	10489	1050	40.38	1095	45.01	1136	49.28	1176	53.50	1214	57.79	1251	62.13	1287	66.53	1322	70.98	1356	75.49	1390	80.05
3000	11238	1054	41.88	1098	46.63	1141	51.50	1182	56.49	1220	60.95	1257	65.48	1293	70.06	1328	74.70	1362	79.39	1395	84.13
3200	11987	1057	43.39	1102	48.26	1144	53.26	1185	58.37	1225	63.60	1263	68.89	1299	73.66	1334	78.48	1368	83.35	1401	88.27
3400	12736	1061	44.92	1105	49.92	1148	55.04	1189	60.28	1229	65.63	1267	71.09	1304	76.66	1340	82.32	1374	87.37	1407	92.48
3600	13486	1065	46.50	1109	51.59	1152	56.84	1193	62.20	1232	67.68	1270	73.26	1308	78.96	1344	84.75	1379	90.65	1413	96.65
3800	14235	1073	49.11	1113	53.54	1155	58.66	1196	64.15	1236	69.75	1274	75.46	1311	81.28	1347	87.20	1382	93.22	1416	99.34
4000	14984	1081	51.79	1121	56.40	1161	61.06	1200	66.12	1239	71.84	1278	77.68	1315	83.62	1351	89.66	1386	95.81	1420	102.0
4200	15733	1089	54.54	1129	59.34	1169	64.18	1207	69.05	1243	73.97	1281	79.92	1318	85.98	1354	92.15	1389	98.42	1424	104.8
4400	16482	1097	57.36	1138	62.35	1177	67.37	1215	72.43	1251	77.53	1286	82.66	1322	88.37	1358	94.67	1393	101.1	1427	107.6
4600	17232	1105	60.26	1146	65.43	1185	70.64	1223	75.88	1259	81.16	1294	86.48	1328	91.83	1362	97.22	1397	103.7	1431	110.3
4800	17981	1114	63.39	1154	68.58	1193	73.98	1231	79.41	1267	84.88	1302	90.38	1336	95.91	1370	101.5	1402	107.1	1434	113.2
5000	18730	1125	66.75	1163	71.99	1201	77.40	1239	83.02	1275	88.67	1310	94.36	1344	100.1	1378	105.8	1410	111.6	1441	117.4
5200	19479	1136	70.22	1174	75.64	1211	81.09	1247	86.71	1283	92.55	1318	98.42	1352	104.3	1386	110.3	1418	116.2	1449	122.2
5400	20228	1147	73.79	1185	79.41	1221	85.05	1257	90.70	1291	96.52	1327	102.6	1361	108.7	1394	114.8	1426	120.9	1457	127.1
5600	20978	1158	77.47	1196	83.29	1232	89.12	1267	94.96	1301	100.8	1335	106.8	1369	113.1	1402	119.4	1434	125.7	1465	132.1
5800	21727	1169	81.27	1207	87.28	1243	93.30	1278	99.34	1312	105.4	1345	111.5	1377	117.6	1410	124.1	1442	130.6	1473	137.2
6000	22476	1181	85.35	1218	91.38	1254	97.61	1289	103.8	1323	110.1	1355	116.4	1387	122.6	1418	128.9	1450	135.6	1482	142.4
6200	23225	1197	90.36	1229	95.61	1265	102.0	1300	108.5	1333	114.9	1366	121.4	1398	127.8	1429	134.3	1459	140.8	1490	147.7
6400	23974	1213	95.57	1244	100.9	1276	106.6	1311	113.2	1344	119.8	1377	126.5	1409	133.2	1440	139.8	1470	146.5	1499	153.2
6600	24724	1230	101.0	1260	106.5	1290	111.9	1322	118.1	1355	124.9	1388	131.8	1420	138.6	1450	145.5	1480	152.4	1510	159.3
6800	25473	1246	10																		



# Model HF29

**Inlet Size: 29" Outside Diameter**

**Inlet Area: 4.518 Sq. Ft.**

**Max Safe Fan Speed: 1,285 RPM**

**Outlet Size: 24-9/16" x 28-1/8" Outside**

**Outlet Area: 4.661 Sq. Ft.**

**Wheel Diameter: 50-1/2"**

**Wheel Circumference: 13.22 Feet**

**Tip Speed (FPM): 13.22 x RPM**

SP	1"		2"		3"		4"		5"		6"		7"		8"		9"		10"		
	OV	CFM	RPM	BHP	RPM	BHP	RPM	BHP	RPM	BHP	RPM	BHP	RPM	BHP	RPM	BHP	RPM	BHP	RPM	BHP	
1000	4661	285	1.51	395	3.45	479	5.48	549	7.71	611	10.18	667	12.80	719	15.57	767	18.48	813	21.52	855	24.67
1200	5593	291	1.76	400	3.92	484	6.24	554	8.66	615	11.24	672	14.02	723	16.98	772	20.07	817	23.30	860	26.64
1400	6525	298	2.08	403	4.26	489	7.02	559	9.68	621	12.47	676	15.40	728	18.44	776	21.70	821	25.11	864	28.64
1600	7458	307	2.45	408	4.68	492	7.53	564	10.73	626	13.75	682	16.90	733	20.17	781	23.54	825	27.02	868	30.69
1800	8390	317	2.88	415	5.29	495	8.05	567	11.43	631	15.07	687	18.45	738	21.94	786	25.54	831	29.24	873	33.04
2000	9322	331	3.46	422	5.94	501	8.77	571	12.12	634	15.92	692	19.97	743	23.76	791	27.58	836	31.51	878	35.53
2200	10254	346	4.12	431	6.69	508	9.69	574	12.86	637	16.78	695	20.97	748	25.39	796	29.68	841	33.83	883	38.08
2400	11186	361	4.87	441	7.51	515	10.66	581	14.05	641	17.65	698	22.00	751	26.57	800	31.35	846	36.21	889	40.69
2600	12119	379	5.80	452	8.43	524	11.74	588	15.30	647	19.01	701	23.04	754	27.77	803	32.70	850	37.81	893	43.11
2800	13051	397	6.86	466	9.60	533	12.93	596	16.60	654	20.54	707	24.55	757	28.99	807	34.07	853	39.34	896	44.79
3000	13983	415	8.05	481	10.89	543	14.18	605	18.06	661	22.13	714	26.37	763	30.69	810	35.46	856	40.89	900	46.49
3200	14915	434	9.37	496	12.29	554	15.61	614	19.63	669	23.80	721	28.26	770	32.80	815	37.41	859	42.46	903	48.22
3400	15847	452	10.84	511	13.82	569	17.37	624	21.28	678	25.69	728	30.21	777	34.98	822	39.82	865	44.72	906	49.96
3600	16780	470	12.30	529	15.66	583	19.26	634	23.02	688	27.66	737	32.34	784	37.23	829	42.30	872	47.43	912	52.61
3800	17712	487	13.83	547	17.67	598	21.29	648	25.24	697	29.73	747	34.65	792	39.60	837	44.86	879	50.21	919	55.63
4000	18644	504	15.49	565	19.86	613	23.47	662	27.66	707	31.89	756	37.05	801	42.24	844	47.49	886	53.08	926	58.72
4200	19576	521	17.29	583	22.23	629	25.86	677	30.22	721	34.57	766	39.56	811	44.99	853	50.44	893	56.03	934	61.90
4400	20508	539	19.24	602	24.79	647	28.64	692	32.95	735	37.54	776	42.17	821	47.84	863	53.54	902	59.26	941	65.17
4600	21441	556	21.35	620	27.56	665	31.62	707	35.85	750	40.68	789	45.43	830	50.80	872	56.74	912	62.70	949	68.69
4800	22373	574	23.62	639	30.53	683	34.82	722	38.94	764	43.99	804	48.98	840	53.92	882	60.06	921	66.27	959	72.49
5000	23305	592	26.06	657	33.47	701	38.23	740	42.57	779	47.49	818	52.72	855	57.89	892	63.50	931	69.95	968	76.42
5200	24237	611	28.82	674	36.40	719	41.88	757	46.43	794	51.18	833	56.65	869	62.05	903	67.41	941	73.75	978	80.47
5400	25169	631	31.85	691	39.52	738	45.77	775	50.53	810	55.16	848	60.77	884	66.42	918	72.01	951	77.68	988	84.64
5600	26102	650	35.08	708	42.83	756	49.90	793	54.88	828	59.72	863	65.11	899	70.99	932	76.82	964	82.59	997	88.95
5800	27034	670	38.55	725	46.33	775	54.29	812	59.49	846	64.54	878	69.66	913	75.78	947	81.84	979	87.85	1009	93.82
6000	27966	690	42.24	742	50.04	794	58.90	830	64.37	863	69.64	895	74.78	928	80.79	962	87.09	993	93.34	1023	99.54
6200	28898	710	46.17	760	53.97	811	63.13	849	69.52	882	75.01	913	80.36	944	86.03	976	92.57	1008	99.06	1038	105.49
6400	29830	730	50.35	777	58.11	828	67.59	867	74.96	900	80.66	930	86.23	960	91.70	991	98.29	1023	105.01	1052	111.68
6600	30763	750	54.78	795	62.48	845	72.27	886	80.69	918	86.61	948	92.40	977	98.07	1007	104.25	1038	111.22	1067	118.13
6800	31695	770	59.48	813	67.08	862	77.19	905	86.72	936	92.87	966	98.87	995	104.76	1022	110.55	1053	117.67	1082	124.8

SP	11"		12"		13"		14"		15"		16"		17"		18"		19"		20"		
	OV	CFM	RPM	BHP	RPM	BHP	RPM	BHP	RPM	BHP	RPM	BHP	RPM	BHP	RPM	BHP	RPM	BHP	RPM	BHP	
2000	9322	919	39.65	957	43.85	994	48.14	1030	52.50	1064	57.00	1098	61.71	1130	66.51	1162	71.40	1192	76.37	1222	81.42
2200	10254	924	42.42	962	46.85	999	51.36	1035	55.95	1069	60.62	1102	65.36	1135	70.17	1166	75.10	1196	80.26	1226	85.50
2400	11186	929	45.26	967	49.91	1004	54.64	1040	59.46	1074	64.35	1107	69.31	1140	74.35	1171	79.46	1201	84.64	1231	89.88
2600	12119	934	48.15	973	53.03	1010	57.99	1045	63.03	1079	68.05	1113	73.34	1145	78.60	1176	83.93	1206	89.33	1236	94.80
2800	13051	938	50.41	978	56.19	1015	61.40	1050	66.67	1085	72.01	1118	77.43	1150	82.92	1181	88.48	1212	94.10	1241	99.79
3000	13983	941	52.26	981	58.20	1019	64.28	1056	70.38	1090	75.95	1123	81.59	1155	87.31	1186	93.09	1217	98.95	1246	104.86
3200	14915	944	54.14	984	60.23	1022	66.47	1059	72.86	1094	79.39	1128	85.83	1160	91.78	1192	97.79	1222	103.87	1252	110.01
3400	15847	948	56.04	987	62.29	1025	68.68	1062	75.23	1097	81.91	1132	88.74	1165	95.70	1197	102.56	1227	108.87	1257	115.24
3600	16780	951	57.97	990	64.37	1029	70.92	1065	77.62	1101	84.46	1135	91.44	1168	98.55	1200	105.79	1232	113.16	1262	120.55
3800	17712	957	61.10	994	66.62	1032	73.18	1068	80.04	1104	87.03	1138	94.16	1171	101.43	1203	108.83	1235	116.35	1265	123.99
4000	18644	965	64.42	1001	70.17	1036	75.97	1072	82.48	1107	89.63	1141	96.92	1174	104.34	1207	111.89	1238	119.57	1268	127.4
4200	19576	972	67.83	1008	73.81	1043	79.84	1077	85.91	1110	92.26	1144	99.70	1178	107.28	1210	114.99	1241	122.82	1272	130.8
4400	20508	979	71.33	1015	77.54	1050	83.80	1084	90.10	1117	96.45	1148	102.85	1181	110.25	1213	118.11	1244	126.1	1275	134.2
4600	21441	986	74.92	1023	81.36	1058	87.85	1091	94.38	1124	100.96	1155	107.58	1186	114.25	1216	121.27	1247	129.4	1278	137.7
4800	22373	994	78.75	1030	85.27	1065	91.99	1099	98.76	1131	105.57	1162	112.42	1193	119.32	1223	126.3	1252	133.2	1281	141.2
5000	23305	1004	82.91	1038	89.42	1072	96.23	1106	103.23	1138	110.27	1170	117.36	1200	124.5	1230	131.6	1259	138.9	1287	146.1
5200	24237	1013	87.20	1047	93.95	1080	100.73	1113	107.81	1145	115.08	1177	122.40	1207	129.8	1237	137.2	1266	144.6	1294	152.1
5400	25169	1023	91.62	1057	98.62	1090	105.63	1121	112.67	1153	120.00	1184	127.5	1214	135.1	1244	142.8	1273	150.4	1301	158.1
5600	26102	1033	96.18	1067	103.42	1099	110.67	1131	117.95	1161	125.2	1191	132.8	1222	140.6	1251	148.5	1280	156.4	1308	164.3
5800	27034	1043	100.87	1076	108.35	1109	115.85	1140	123.37	1170	130.9	1200	138.5	1229	146.2	1258	154.3	1287	162.5	1315	170.6
6000	27966	1052	105.70	1086	113.44	1118	121.18	1150	128.9	1180	136.7	1209	144.5	1238	152.3	1266	160.3	1294	168.6	1322	177.0
6200	28898	1067	111.88	1096	118.66	1128	126.7	1159	134.7	1190	142.7	1219	150.7	1247	158.8	1275	166.8	1302	174.9	1330	183.6
6400	29830	1081	118.31	1109	124.9	1138	132.3	1169	140.5	1199	148.8	1228	157.1	1257	165.4	1284	173.7	1311	182.0	1337	190.4
6600	30763	1096	125.0	1123	131.8	1149	138.6	1179	146.6	1209	155.1	1238	163.6	1266	172.1	1294	180.7	1321	189.3	1347	197.8
6800	31695</																				

Inlet Size: 33" Outside Diameter

Inlet Area: 5.861 Sq. Ft.

Max Safe Fan Speed: 1,130 RPM

# Model HF33

Outlet Size: 28-3/16" x 31-15/16" Outside

Outlet Area: 6.045 Sq. Ft.

Wheel Diameter: 57-1/2"

Wheel Circumference: 15.05 Feet

Tip Speed (FPM): 15.05 x RPM

SP		1"		2"		3"		4"		5"		6"		7"		8"		9"		10"	
OV	CFM	RPM	BHP	RPM	BHP	RPM	BHP	RPM	BHP	RPM	BHP	RPM	BHP	RPM	BHP	RPM	BHP	RPM	BHP	RPM	BHP
1000	6045	251	1.96	347	4.47	420	7.11	482	10.00	537	13.20	586	16.60	632	20.19	674	23.96	714	27.90	751	31.99
1200	7254	255	2.28	351	5.08	425	8.09	486	11.24	541	14.57	590	18.18	635	22.02	678	26.03	717	30.21	755	34.54
1400	8463	262	2.69	354	5.52	429	9.11	491	12.55	545	16.18	594	19.97	639	23.91	681	28.14	721	32.56	759	37.14
1600	9672	270	3.18	358	6.06	432	9.76	495	13.91	550	17.83	599	21.92	644	26.15	686	30.53	725	35.04	762	39.79
1800	10881	278	3.73	364	6.86	435	10.43	498	14.82	554	19.54	603	23.92	648	28.45	690	33.12	729	37.92	767	42.85
2000	12090	291	4.48	371	7.70	440	11.38	501	15.71	557	20.64	608	25.89	653	30.81	695	35.77	734	40.86	771	46.08
2200	13299	304	5.34	379	8.68	446	12.57	504	16.67	560	21.75	610	27.20	657	32.93	699	38.49	739	43.88	776	49.39
2400	14508	317	6.32	387	9.74	452	13.82	511	18.23	563	22.88	613	28.53	660	34.46	703	40.65	743	46.96	780	52.77
2600	15717	333	7.53	397	10.93	460	15.23	517	19.84	568	24.65	616	29.88	662	36.01	706	42.40	746	49.03	785	55.90
2800	16926	348	8.90	409	12.46	468	16.77	523	21.53	574	26.64	621	31.85	665	37.59	708	44.18	749	51.01	787	58.08
3000	18135	365	10.44	422	14.12	477	18.39	531	23.43	581	28.70	627	34.21	670	39.80	711	45.98	752	53.02	790	60.29
3200	19344	381	12.16	435	15.94	487	20.25	539	25.47	587	30.87	633	36.65	676	42.54	716	48.52	755	55.06	793	62.52
3400	20553	397	14.07	449	17.93	500	22.54	548	27.61	596	33.32	640	39.18	682	45.37	722	51.64	760	57.99	796	64.79
3600	21762	413	15.96	464	20.32	512	24.99	557	29.86	604	35.88	647	41.95	689	48.29	728	54.86	766	61.51	801	68.23
3800	22971	428	17.94	480	22.93	525	27.63	569	32.75	613	38.57	656	44.94	696	51.36	735	58.18	772	65.13	807	72.15
4000	24180	443	20.09	496	25.77	539	30.45	582	35.88	621	41.37	664	48.06	704	54.79	741	61.59	778	68.84	814	76.16
4200	25389	458	22.43	512	28.84	553	33.56	595	39.21	633	44.85	673	51.31	712	58.35	749	65.43	785	72.67	820	80.29
4400	26598	473	24.97	528	32.17	568	37.16	608	42.75	646	48.70	681	54.69	721	62.05	758	69.44	792	76.86	826	84.52
4600	27807	489	27.70	545	35.76	584	41.03	621	46.51	658	52.77	693	58.94	729	65.89	766	73.60	801	81.33	834	89.10
4800	29016	504	30.65	561	39.62	600	45.18	634	50.52	671	57.07	706	63.54	738	69.95	775	77.90	809	85.95	842	94.03
5000	30225	520	33.82	577	43.43	616	49.61	650	55.23	685	61.61	719	68.39	751	75.10	783	82.36	818	90.73	850	99.12
5200	31434	537	37.40	592	47.23	632	54.34	665	60.24	698	66.39	732	73.49	764	80.50	794	87.45	826	95.67	859	104.37
5400	32643	554	41.33	607	51.28	648	59.39	681	65.57	712	71.56	745	78.85	776	86.17	806	93.41	835	100.77	867	109.79
5600	33852	571	45.53	622	55.57	665	64.75	697	71.21	727	77.49	758	84.47	789	92.10	819	99.65	847	107.15	876	115.39
5800	35061	589	50.02	637	60.12	681	70.45	713	77.19	743	83.75	771	90.37	802	98.32	832	106.18	860	113.97	886	121.71
6000	36270	606	54.81	652	64.93	698	76.42	729	83.52	759	90.36	786	97.03	816	104.82	845	112.99	872	121.09	899	129.13
6200	37479	624	59.92	667	70.03	712	81.92	745	90.21	774	97.33	802	104.27	829	111.62	858	120.10	885	128.51	912	136.85
6400	38688	641	65.34	683	75.40	727	87.70	762	97.27	790	104.66	817	111.89	843	118.98	871	127.52	898	136.24	924	144.89
6600	39897	659	71.10	698	81.07	742	93.78	778	104.71	806	112.39	833	119.89	858	127.25	884	135.26	911	144.29	937	153.25
6800	41106	676	77.19	714	87.05	757	100.16	795	112.54	823	120.50	849	128.29	874	135.93	898	143.43	925	152.67	950	161.9

SP		11"		12"		13"		14"		15"		16"		17"		18"		19"		20"	
OV	CFM	RPM	BHP	RPM	BHP	RPM	BHP	RPM	BHP	RPM	BHP	RPM	BHP	RPM	BHP	RPM	BHP	RPM	BHP	RPM	BHP
2000	12090	807	51.42	841	56.86	873	62.42	904	68.08	935	73.91	964	80.02	992	86.24	1020	92.58	1047	99.03	1073	105.58
2200	13299	811	55.01	845	60.75	878	66.60	909	72.55	939	78.60	968	84.75	996	91.00	1024	97.38	1051	104.07	1077	110.87
2400	14508	816	58.69	850	64.72	882	70.86	913	77.10	943	83.45	973	89.88	1001	96.42	1028	103.04	1055	109.75	1081	116.55
2600	15717	820	62.44	854	68.77	887	75.20	918	81.74	948	88.37	977	95.10	1005	101.93	1033	108.84	1060	115.84	1086	122.93
2800	16926	824	65.36	859	72.86	891	79.63	922	86.46	953	93.39	982	100.41	1010	107.53	1037	114.74	1064	122.03	1090	129.41
3000	18135	827	67.77	862	75.46	895	83.36	927	91.27	957	98.49	986	105.81	1015	113.23	1042	120.73	1069	128.31	1095	135.99
3200	19344	829	70.21	864	78.10	898	86.19	930	94.48	961	102.95	991	111.31	1019	119.02	1047	126.81	1073	134.70	1099	142.66
3400	20553	832	72.67	867	80.77	901	89.06	933	97.55	964	106.22	994	115.06	1023	124.09	1051	133.00	1078	141.18	1104	149.44
3600	21762	835	75.17	870	83.47	903	91.96	936	100.65	967	109.52	997	118.57	1026	127.79	1054	137.18	1082	146.73	1108	156.33
3800	22971	841	79.24	873	86.40	906	94.90	938	103.79	969	112.86	1000	122.10	1029	131.53	1057	141.11	1084	150.87	1111	160.78
4000	24180	847	83.55	879	91.01	910	98.53	941	106.96	972	116.23	1002	125.68	1031	135.30	1060	145.09	1087	155.04	1114	165.2
4200	25389	854	87.98	886	95.73	916	103.54	946	111.43	975	119.64	1005	129.29	1034	139.11	1063	149.10	1090	159.26	1117	169.6
4400	26598	860	92.51	892	100.56	923	108.68	952	116.85	981	125.09	1009	133.39	1037	142.96	1065	153.16	1093	163.5	1120	174.0
4600	27807	866	97.17	898	105.52	929	113.93	959	122.41	987	130.94	1015	139.53	1042	148.18	1068	157.25	1096	167.8	1122	178.5
4800	29016	873	102.14	905	110.60	935	119.31	965	128.09	993	136.92	1021	145.80	1048	154.75	1074	163.7	1099	172.8	1125	183.1
5000	30225	882	107.54	912	115.99	942	124.82	971	133.89	1000	143.02	1027	152.21	1054	161.4	1080	170.7	1105	180.1	1130	189.5
5200	31434	890	113.10	920	121.86	949	130.65	978	139.83	1006	149.26	1034	158.75	1060	168.3	1086	177.9	1112	187.5	1136	197.2
5400	32643	899	118.84	928	127.91	957	137.01	985	146.14	1012	155.64	1040	165.4	1067	175.3	1093	185.2	1118	195.1	1143	205.1
5600	33852	907	124.75	937	134.14	965	143.55	993	152.99	1020	162.5	1046	172.2	1073	182.4	1099	192.6	1124	202.8	1149	213.1
5800	35061	916	130.84	945	140.55	974	150.27	1001	160.02	1028	169.8	1054	179.6	1079	189.7	1105	200.2	1131	210.7	1155	221.3
6000	36270	924	137.12	954	147.14	982	157.18	1010	167.2	1036	177.3	1062	187.4	1087	197.6	1112	207.9	1137	218.7	1162	229.6
6200	37479	937	145.14	963	153.92	991	164.3	1018	174.7	1045	185.1	1071	195.5	1095	205.9	1120	216.4	1143	226.9	1168	238.1
6400	38688	950	153.48	974	162.0	1000	171.6	1027	182.3	1053	193.0	1079	203.7	1104	214.5	1128	225.3	1152	236.1	1175	246.9
6600	39897	962	162.1	986	171.0	1010	179.8	1035	190.1	1062	201.1	1087	212.2	1112	223.3	1136	234.4	1160	245.5	1183	256.6
6800	41106	975</																			



# Model HF37

**Inlet Size: 37" Outside Diameter**

**Inlet Area: 7.379 Sq. Ft.**

**Max Safe Fan Speed: 1,010 RPM**

**Outlet Size: 31-5/16" x 35-15/16" Outside**

**Outlet Area: 7.583 Sq. Ft.**

**Wheel Diameter: 64-3/8"**

**Wheel Circumference: 16.85 Feet**

**Tip Speed (FPM): 16.85 x RPM**

SP		1"		2"		3"		4"		5"		6"		7"		8"		9"		10"	
OV	CFM	RPM	BHP	RPM	BHP	RPM	BHP	RPM	BHP	RPM	BHP	RPM	BHP	RPM	BHP	RPM	BHP	RPM	BHP	RPM	BHP
1000	7583	224	2.46	310	5.61	375	8.91	431	12.54	479	16.55	524	20.81	564	25.32	602	30.05	637	34.98	671	40.11
1200	9100	228	2.86	314	6.37	379	10.15	434	14.09	483	18.27	527	22.79	567	27.61	605	32.64	641	37.88	674	43.31
1400	10616	234	3.38	316	6.93	384	11.42	438	15.74	487	20.29	531	25.04	571	29.99	609	35.29	644	40.83	678	46.57
1600	12133	241	3.99	320	7.61	386	12.24	443	17.45	491	22.37	535	27.49	575	32.80	612	38.29	648	43.95	681	49.90
1800	13649	249	4.68	325	8.60	389	13.08	445	18.58	495	24.51	539	30.00	579	35.68	616	41.54	652	47.56	685	53.73
2000	15166	260	5.63	331	9.66	393	14.27	448	19.70	498	25.89	543	32.46	583	38.64	620	44.86	656	51.25	689	57.79
2200	16683	271	6.71	338	10.89	398	15.77	450	20.92	500	27.28	545	34.10	587	41.29	625	48.27	660	55.03	693	61.94
2400	18199	283	7.93	346	12.22	404	17.34	456	22.86	503	28.70	548	35.77	589	43.21	628	50.97	664	58.90	697	66.18
2600	19716	297	9.46	354	13.72	411	19.11	462	24.89	508	30.93	550	37.47	592	45.16	630	53.17	666	61.49	701	70.09
2800	21232	311	11.18	366	15.64	418	21.04	467	27.01	513	33.42	555	39.95	594	47.14	633	55.40	669	63.97	703	72.83
3000	22749	326	13.11	377	17.73	426	23.08	474	29.40	519	36.01	560	42.91	598	49.93	635	57.67	671	66.49	706	75.60
3200	24266	340	15.27	389	20.01	435	25.42	482	31.95	525	38.73	566	45.98	604	53.37	640	60.86	674	69.04	708	78.40
3400	25782	355	17.67	401	22.51	446	28.29	490	34.64	532	41.80	572	49.15	610	56.92	645	64.78	678	72.75	711	81.25
3600	27299	369	20.04	415	25.52	458	31.37	497	37.46	540	45.02	578	52.63	615	60.58	651	68.82	684	77.16	716	85.60
3800	28815	382	22.52	429	28.79	470	34.68	508	41.10	547	48.39	586	56.39	621	64.44	656	72.99	690	81.70	721	90.51
4000	30332	396	25.23	443	32.36	481	38.22	520	45.04	555	51.91	593	60.31	629	68.74	662	77.27	695	86.37	727	95.55
4200	31849	409	28.17	458	36.22	494	42.14	531	49.22	566	56.30	601	64.38	636	73.22	669	82.09	701	91.16	732	100.72
4400	33365	423	31.35	472	40.40	508	46.66	543	53.67	577	61.13	609	68.63	644	77.86	677	87.13	708	96.44	738	106.04
4600	34882	437	34.79	487	44.91	522	51.52	555	58.39	588	66.24	619	73.98	652	82.68	684	92.35	715	102.05	745	111.79
4800	36398	451	38.49	502	49.76	536	56.73	567	63.43	600	71.64	631	79.76	660	87.80	692	97.75	723	107.85	752	117.98
5000	37915	465	42.47	516	54.53	550	62.30	581	69.35	612	77.34	642	85.85	671	94.26	700	103.35	731	113.84	760	124.37
5200	39432	480	46.98	529	59.31	565	68.24	595	75.64	624	83.35	654	92.25	682	101.05	709	109.76	738	120.04	767	130.96
5400	40948	495	51.91	542	64.38	579	74.58	609	82.33	636	89.86	666	98.98	694	108.16	720	117.25	746	126.44	775	137.77
5600	42465	511	57.19	556	69.77	594	81.32	623	89.42	650	97.30	677	106.04	705	115.61	732	125.09	757	134.49	783	144.79
5800	43981	526	62.83	569	75.49	609	88.47	637	96.94	664	105.16	689	113.45	717	123.42	743	133.28	768	143.06	792	152.76
6000	45498	542	68.85	583	81.54	623	95.95	652	104.89	678	113.46	703	121.83	729	131.58	755	141.83	780	151.99	803	162.08
6200	47015	557	75.27	596	87.94	636	102.85	666	113.28	692	122.21	716	130.93	741	140.12	766	150.76	791	161.31	815	171.78
6400	48531	573	82.08	610	94.69	650	110.11	681	122.15	706	131.43	730	140.50	753	149.39	778	160.08	803	171.02	826	181.87
6600	50048	589	89.31	624	101.81	663	117.75	696	131.49	721	141.13	744	150.55	767	159.78	790	169.80	814	181.13	838	192.37
6800	51564	605	96.97	638	109.32	676	125.76	710	141.33	735	151.32	759	161.10	781	170.68	802	180.10	826	191.65	849	203.3

SP		11"		12"		13"		14"		15"		16"		17"		18"		19"		20"	
OV	CFM	RPM	BHP	RPM	BHP	RPM	BHP	RPM	BHP	RPM	BHP	RPM	BHP	RPM	BHP	RPM	BHP	RPM	BHP	RPM	BHP
2000	15166	721	64.48	751	71.31	780	78.28	808	85.38	835	92.68	861	100.34	887	108.15	911	116.09	935	124.17	959	132.39
2200	16683	725	69.00	755	76.19	784	83.53	812	90.99	839	98.58	865	106.29	890	114.12	915	122.11	939	130.50	962	139.03
2400	18199	729	73.61	759	81.17	788	88.87	816	96.70	843	104.65	869	112.72	894	120.92	919	129.22	942	137.64	966	146.17
2600	19716	733	78.31	763	86.25	792	94.32	820	102.51	847	110.83	873	119.27	898	127.83	923	136.50	946	145.28	970	154.17
2800	21232	736	81.96	767	91.36	796	99.87	824	108.44	851	117.13	877	125.93	902	134.86	927	143.90	951	153.04	974	162.30
3000	22749	738	84.98	770	94.63	799	104.52	828	114.47	855	123.53	881	132.71	906	142.01	931	151.41	955	160.93	978	170.55
3200	24266	741	88.04	772	97.94	802	108.08	831	118.47	858	129.09	885	139.60	910	149.27	935	159.05	959	168.93	982	178.93
3400	25782	743	91.13	775	101.28	804	111.68	833	122.32	861	133.19	888	144.28	914	155.60	939	166.81	963	177.07	986	187.43
3600	27299	746	94.27	777	104.67	807	115.32	836	126.21	863	137.33	890	148.68	916	160.24	942	172.01	966	183.99	990	196.07
3800	28815	751	99.40	780	108.38	809	119.00	838	130.15	866	141.52	893	153.12	919	164.93	944	176.95	969	189.18	993	201.61
4000	30332	757	104.81	786	114.16	813	123.60	841	134.13	868	145.75	895	157.60	921	169.67	947	181.94	971	194.42	995	207.1
4200	31849	762	110.37	791	120.09	819	129.89	845	139.78	871	150.03	898	162.13	924	174.45	949	186.98	974	199.71	998	212.6
4400	33365	768	116.06	797	126.16	824	136.34	851	146.59	876	156.92	901	167.33	926	179.28	952	192.06	976	205.0	1000	218.2
4600	34882	774	121.90	802	132.38	830	142.93	856	153.56	882	164.26	907	175.03	930	185.88	954	197.20	979	210.4	1003	223.9
4800	36398	780	128.15	808	138.75	835	149.68	862	160.68	887	171.76	912	182.90	936	194.12	959	205.4	982	216.8	1005	229.6
5000	37915	788	134.93	814	145.53	841	156.59	868	167.97	893	179.42	918	190.94	942	202.5	965	214.2	987	225.9	1010	237.7
5200	39432	795	141.91	822	152.90	848	163.93	873	175.42	899	187.25	923	199.15	947	211.1	970	223.1	993	235.2	1015	247.4
5400	40948	803	149.12	829	160.49	855	171.91	880	183.36	904	195.25	929	207.5	953	219.9	976	232.3	999	244.7	1021	257.3
5600	42465	810	156.53	837	168.31	863	180.11	887	191.95	911	203.8	935	216.1	959	228.8	982	241.6	1004	254.4	1026	267.3
5800	43981	818	164.18	845	176.35	870	188.55	895	200.78	918	213.0	941	225.3	964	237.9	987	251.1	1010	264.3	1032	277.6
6000	45498	826	172.10	852	184.63	878	197.23	902	209.8	926	222.5	949	235.2	971	247.9	993	260.8	1016	274.4	1038	288.1
6200	47015	837	182.18	860	193.14	885	206.1	910	219.2	933	232.2	956	245.3	979	258.4	1000	271.5	1021	284.7	1043	298.7
6400	48531	848	192.65	870	203.4	893	215.3	917	228.7	941	242.2	964	255.6	986	269.1	1008	282.7	1029	296.2	1049	309.8
6600	50048	860	203.5	881	214.6	902	225.7	925	238.5	949	252.4	972	266.3	994	280.1	1015	294.1	1036	308.0	1057	322.0
6800	51564																				



Inlet Size: 41" Outside Diameter

Inlet Area: 9.071 Sq. Ft.

Max Safe Fan Speed: 910 RPM

# Model HF41

Outlet Size: 34-11/16" x 39-11/16" Outside

Outlet Area: 9.240 Sq. Ft.

Wheel Diameter: 71-1/4"

Wheel Circumference: 18.65 Feet

Tip Speed (FPM): 18.65 x RPM

SP		1"		2"		3"		4"		5"		6"		7"		8"		9"		10"	
OV	CFM	RPM	BHP	RPM	BHP	RPM	BHP	RPM	BHP	RPM	BHP	RPM	BHP	RPM	BHP	RPM	BHP	RPM	BHP	RPM	BHP
1000	9240	202	3.01	280	6.84	339	10.88	389	15.32	433	20.22	473	25.43	510	30.94	544	36.72	576	42.76	606	49.03
1200	11088	206	3.48	284	7.78	343	12.38	392	17.20	436	22.30	476	27.84	513	33.73	547	39.88	579	46.29	609	52.93
1400	12936	211	4.11	286	8.46	346	13.94	396	19.21	440	24.76	479	30.57	516	36.61	550	43.10	582	49.88	612	56.90
1600	14784	217	4.86	289	9.27	349	14.95	400	21.29	443	27.29	483	33.54	519	40.03	553	46.74	585	53.65	615	60.95
1800	16632	224	5.69	294	10.48	351	15.98	402	22.70	447	29.90	487	36.60	523	43.54	557	50.69	589	58.04	619	65.59
2000	18480	234	6.83	299	11.76	355	17.39	404	24.06	449	31.62	490	39.66	527	47.14	560	54.74	592	62.54	622	70.53
2200	20328	245	8.14	305	13.25	360	19.21	407	25.49	452	33.32	492	41.66	530	50.44	564	58.89	596	67.14	626	75.58
2400	22176	255	9.61	312	14.86	365	21.12	412	27.85	454	35.04	495	43.69	532	52.78	567	62.26	600	71.84	630	80.74
2600	24024	268	11.45	320	16.65	371	23.26	417	30.32	458	37.68	497	45.76	534	55.15	569	64.94	602	75.11	633	85.64
2800	25872	280	13.53	330	18.97	378	25.59	422	32.89	463	40.71	501	48.67	537	57.56	572	67.66	604	78.14	635	88.96
3000	27720	293	15.86	340	21.51	384	28.07	428	35.77	468	43.85	506	52.27	540	60.83	574	70.42	607	81.20	637	92.34
3200	29568	306	18.47	351	24.27	392	30.85	435	38.87	474	47.13	511	56.00	545	65.01	577	74.16	609	84.31	640	95.75
3400	31416	320	21.36	361	27.27	402	34.33	442	42.13	480	50.86	516	59.85	550	69.33	582	78.92	613	88.64	642	99.21
3600	33264	332	24.27	374	30.89	413	38.06	449	45.56	487	54.77	522	64.04	555	73.78	587	83.83	618	94.00	646	104.29
3800	35112	344	27.27	386	34.85	423	42.06	458	49.88	494	58.86	529	68.61	561	78.42	593	88.89	623	99.52	651	110.26
4000	36960	356	30.54	399	39.16	434	46.35	468	54.64	501	63.12	535	73.36	567	83.64	598	94.09	628	105.19	656	116.38
4200	38808	368	34.09	412	43.82	445	51.02	479	59.71	510	68.33	542	78.31	574	89.07	604	99.89	633	111.01	661	122.67
4400	40656	381	37.94	425	48.87	457	56.50	489	65.09	520	74.18	549	83.46	581	94.71	611	106.00	639	117.35	666	129.13
4600	42504	393	42.09	438	54.31	470	62.37	500	70.80	530	80.36	558	89.79	588	100.56	618	112.34	646	124.16	672	136.03
4800	44352	406	46.56	452	60.17	483	68.66	511	76.86	541	86.90	569	96.79	595	106.63	624	118.89	652	131.20	679	143.55
5000	46200	418	51.36	464	66.05	495	75.39	523	83.97	551	93.79	579	104.16	605	114.40	631	125.68	659	138.47	686	151.30
5200	48048	432	56.75	476	71.82	508	82.57	535	91.58	562	101.07	589	111.90	615	122.61	639	133.23	666	145.99	692	159.30
5400	49896	445	62.70	488	77.96	521	90.22	548	99.65	573	108.81	600	120.04	625	131.22	649	142.30	673	153.76	699	167.56
5600	51744	459	69.07	500	84.47	535	98.36	561	108.22	585	117.80	610	128.59	636	140.24	660	151.78	682	163.23	706	176.07
5800	53592	473	75.88	512	91.37	548	107.00	574	117.30	598	127.31	621	137.56	646	149.69	670	161.70	692	173.60	714	185.43
6000	55440	487	83.14	525	98.68	561	116.17	587	126.90	610	137.34	633	147.52	657	159.57	680	172.05	703	184.42	724	196.71
6200	57288	501	90.88	537	106.41	573	124.58	600	137.05	623	147.91	645	158.52	667	169.90	691	182.86	713	195.70	734	208.45
6400	59136	515	99.10	549	114.56	585	133.35	613	147.75	636	159.05	658	170.08	678	180.90	701	194.13	723	207.45	745	220.66
6600	60984	529	107.82	562	123.16	597	142.57	626	159.04	649	170.76	670	182.23	691	193.47	712	205.89	734	219.68	755	233.37
6800	62832	544	117.06	574	132.22	609	152.26	639	170.91	662	183.08	683	194.97	703	206.63	723	218.13	744	232.41	765	246.6

SP		11"		12"		13"		14"		15"		16"		17"		18"		19"		20"	
OV	CFM	RPM	BHP	RPM	BHP	RPM	BHP	RPM	BHP	RPM	BHP	RPM	BHP	RPM	BHP	RPM	BHP	RPM	BHP	RPM	BHP
2000	18480	651	78.70	678	87.05	704	95.56	730	104.23	754	113.21	778	122.57	801	132.11	823	141.82	845	151.70	866	161.75
2200	20328	655	84.20	682	92.99	708	101.94	733	111.06	758	120.33	781	129.75	804	139.31	826	149.15	848	159.41	869	169.83
2400	22176	658	89.80	685	99.04	712	108.45	737	118.01	761	127.72	785	137.58	808	147.59	830	157.74	851	168.02	872	178.44
2600	24024	662	95.53	689	105.22	715	115.07	741	125.08	765	135.25	788	145.55	811	156.00	833	166.59	855	177.32	876	188.18
2800	25872	665	100.13	693	111.52	719	121.83	744	132.29	769	142.90	792	153.66	815	164.56	837	175.60	859	186.77	879	198.07
3000	27720	667	103.81	695	115.60	722	127.70	748	139.63	772	150.70	796	161.91	819	173.26	841	184.74	862	196.36	883	208.11
3200	29568	669	107.53	697	119.63	724	132.03	750	144.73	775	157.71	799	170.29	822	182.10	844	194.04	866	206.11	887	218.31
3400	31416	671	111.30	700	123.70	727	136.41	753	149.41	778	162.70	802	176.27	825	190.10	848	203.48	870	216.01	890	228.66
3600	33264	674	115.11	702	127.82	729	140.84	755	154.15	780	167.75	804	181.61	828	195.75	851	210.14	873	224.79	894	239.17
3800	35112	678	121.11	704	132.06	731	145.32	757	158.94	782	172.84	806	187.02	830	201.46	853	216.15	875	231.10	897	246.30
4000	36960	683	127.69	709	139.09	734	150.60	759	163.78	784	177.99	809	192.48	832	207.22	855	222.23	877	237.48	899	253.0
4200	38808	688	134.43	714	146.29	739	158.25	763	170.31	787	183.20	811	197.99	834	213.05	857	228.36	879	243.92	901	259.7
4400	40656	693	141.35	719	153.67	744	166.08	768	178.59	791	191.19	813	203.89	837	218.93	860	234.55	882	250.4	903	266.5
4600	42504	699	148.44	724	161.22	749	174.10	773	187.06	796	200.11	818	213.26	840	226.49	862	240.80	884	257.0	906	273.4
4800	44352	704	155.95	729	168.96	754	182.30	778	195.72	801	209.23	823	222.82	845	236.50	866	250.3	887	264.1	908	280.3
5000	46200	711	164.17	735	177.10	759	190.69	783	204.57	806	218.54	828	232.59	850	246.7	871	260.9	892	275.2	911	289.6
5200	48048	718	172.65	742	186.05	765	199.49	788	213.62	811	228.05	834	242.56	855	257.2	876	271.8	897	286.6	916	301.4
5400	49896	724	181.39	748	195.26	772	209.17	794	223.13	816	237.77	839	252.7	860	267.8	881	282.9	902	298.1	921	313.4
5600	51744	731	190.39	755	204.74	778	219.13	801	233.56	822	248.0	844	263.1	865	278.7	886	294.3	907	309.9	927	325.7
5800	53592	738	199.66	762	214.50	785	229.37	807	244.28	829	259.2	850	274.2	870	289.7	891	305.8	912	321.9	932	338.1
6000	55440	745	209.21	769	224.54	792	239.90	814	255.3	835	270.7	856	286.2	876	301.7	896	317.6	917	334.2	937	350.8
6200	57288	755	221.11	776	234.87	799	250.7	821	266.6	842	282.5	863	298.4	883	314.4	903	330.4	922	346.6	942	363.8
6400	59136	765	233.79	784	246.8	806	261.8	828	278.2	849	294.6	870	311.0	890	327.4	909	343.9	928	360.5	947	377.0
6600	60984	775	247.0	795	260.5	813	273.9	835	290.1	856	307.0	877	323.9	897	340.8	916	357.8	935	374.8	954	391.8
6800	62832	785	260.6	805	274.6																



Standard HF series fan with a medium pressure pulse cleaning baghouse filter.



One of two negative system backward curve fans with a medium pressure cleaning baghouse filter.



In house fan blade balancer capable of balancing blades from 12" to 72" diameter.



6" direct drive fan in an agriculture application. This fan is pulling dust off of (2) grain bucket elevators.

FAN SIZE & Model	A	B	C	D	E	F	G	H	I	J	K	L	M
HF6	5-1/2	4-1/4	11-1/4	6	8-7/8	8-11/16	19-1/8	20-3/16	21-11/16	4-7/8	18-5/16	15-7/8	14-1/4
HF8	7-1/4	5-3/4	12-3/4	8	11	10-15/16	22-7/8	23-3/4	24-11/16	4-9/16	23	17-3/4	16-1/4
HF9	9-1/16	8	17-7/8	9	11-7/16	11-3/16	24-1/8	29-5/16	30-13/16	3-7/8	23-11/16	15	13-1/4
HF11	10-3/4	9-7/16	18	11	14	13-11/16	29-1/2	32	33-13/16	4-3/4	29	18	15
HF13	12-7/8	11-1/8	20-7/8	13	16-1/4	15-15/16	34-3/4	37-1/8	39-11/16	5-5/8	33-3/4	21	17-3/4
HF15	14-3/4	12-3/4	23-7/16	15	18-3/8	18-3/16	39-7/8	41-13/16	45-1/8	6-5/8	38-1/4	23-1/2	19-5/8
HF17	16-1/2	14-1/2	26-15/16	17	20-1/2	20-3/8	44-7/8	47-7/16	51-7/16	7-5/8	43	26	22-1/4
HF19	18-3/8	16	30-1/16	19	22-5/8	22-3/4	50-1/8	52-11/16	57-7/16	8-3/4	47-7/8	29	24-7/8
HF21	20-3/8	17-11/16	33-3/16	21	24-9/16	25-1/8	55-1/4	57-3/4	63-5/8	9-3/8	52-1/4	31-1/2	27-3/8
HF23	22-7/16	19-9/16	35-3/8	23	26-3/4	27-9/16	60-5/8	62-1/8	68-7/16	10-1/4	57-1/4	34-1/4	29-1/2
HF26	25-5/16	22	39-1/2	26	29-7/8	30-7/8	67-3/4	69-3/8	76-3/8	11-1/4	64-1/8	38-5/8	34
HF29	28-1/8	24-9/16	43-1/2	29	33-1/8	34-9/16	75-7/8	77-7/16	85-5/8	12-3/4	71-1/4	42-7/8	38-1/4
HF33	31-15/16	28-3/16	49-1/2	33	37-3/8	39-3/8	86-3/8	86-7/8	96-1/2	14-3/4	80-3/4	48-1/8	43-1/2
HF37	35-15/16	31-5/16	51-1/4	37	42-5/8	44-1/8	97-1/8	93-7/8	104-1/4	16-3/4	91-1/8	53-3/4	49-1/8
HF41	39-11/16	34-11/16	56-1/2	41	46-3/4	48-3/4	107-3/8	103-1/4	115-1/8	18-1/2	100-1/2	59	54-3/8

FAN SIZE & Model	T	U	V	W	X	Y	Z	AA	BB	CC	DD	EE
HF6	15-5/8	1-5/8	4-13/16	22	13/32	3-9/16	15/16	24-3/4	18-1/4	9-5/16	8-5/16	9-1/16
HF8	17-3/4	1-5/8	5-13/16	23-13/16	13/32	3-9/16	15/16	28-3/4	22-1/4	12	10-1/4	11-1/2
HF9	15	2	7-3/8	34-5/16	9/16x1	4-1/2	1-3/8	35-1/8	23-3/8	12-3/4	10-5/8	11-11/16
HF11	17-3/4	3	9-5/16	39-15/16	9/16x1	4-1/2	2	38-7/8	28-1/2	15-1/2	13	14-1/4
HF13	19-3/4	3	10-1/8	42-3/8	9/16x1	4-9/16	2	45-5/8	34	19	15	16-1/2
HF15	21-5/8	3	11	46	11/16x1	5-5/16	2	51-11/16	38	20-3/4	17-1/4	17
HF17	24-1/4	3	11-7/8	48-1/8	11/16x1	5-5/16	2	58-11/16	43	23-1/2	19-1/2	21-1/4
HF19	27-1/2	3	14-1/16	52-1/16	13/16x1-1/4	5-3/8	2	65-5/16	45-3/4	24	21-3/4	26-1/2
HF21	30	3	14-15/16	55-15/16	13/16x1-1/4	6-1/2	2	71-11/16	53	29	24	26-1/2
HF23	32-1/8	3	15-7/8	58-3/8	13/16x1-1/4	6-9/16	2	77-3/8	58	32	26	29
HF26	36-3/4	3	18-5/8	65-3/16	13/16x1-1/4	6-11/16	2	86-1/2	65	35-1/2	29-1/2	32-1/2
HF29	41	3	19-7/8	74-1/16	13/16x1-1/4	9-1/16	2	96-13/16	73	40	33	36-1/2
HF33	46-1/4	4	21-11/16	82-1/8	1-1/16x1-1/2	9-5/8	2	109	82-1/2	45	37-1/2	41-1/2
HF37	51-7/8	4	23-5/16	91-1/8	1-1/16x1-1/2	12	3	118-3/4	87-1/2	51	46-1/2	42
HF41	57-1/8	5	24-15/16	99-15/16	1-1/16x1-1/2	12	3	130-3/4	102-9/16	53-9/16	48-3/4	50-1/4



	N	O	P	Q	R	S
	11-7/16	9-3/4	2-1/8	3-3/4	3	3
	11-1/2	9-3/4	2-15/16	4-9/16	3-13/16	3-13/16
	16-1/4	10-1/4	6-3/16	6-3/16	9-3/16	5-5/16
	19-1/4	13-1/4	6-7/8	7-7/8	9-7/8	6-9/16
	20	14	7-11/16	8-11/16	10-11/16	7-3/8
	21-1/8	15-1/4	8-9/16	9-9/16	11-5/8	8-1/4
	21-1/4	15-1/4	9-7/16	10-7/16	12-7/16	9-1/8
	21-1/4	15-1/4	10-5/8	11-1/8	13-11/16	9-13/16
	22-1/2	16-1/2	12	12	15	10-11/16
	23	17	12-15/16	12-15/16	15-15/16	11-5/8
	25-5/8	19-1/2	14-1/4	14-1/4	17-5/16	12-15/16
	29-5/8	23-1/2	15-1/2	15-1/2	18-9/16	14-3/16
	33	27	17-7/8	18-3/8	20-15/16	16-9/16
	36-3/8	30-3/8	19-3/8	19-15/16	22-7/16	18-1/8
	40-7/8	34-7/8	21-3/16	22-11/16	24-1/4	20-3/8

FF	CFM	Weight in Pounds			
	4,000-6,000 FPM	8"-12" SP	STD	HD	XHD
13-1/2	600-875	98	103	114	122
16	1,075-1,625	121	131	148	154
17-1/4	1,900-2,875	226	253	306	330
20-7/8	2,650-4,000	328	370	428	465
24-3/4	3,800-5,700	396	450	527	576
28-1/4	5,000-7,500	497	568	676	731
31-3/4	6,400-9,600	606	696	832	900
35-1/4	7,900-11,900	824	949	1109	1204
38-1/2	9,700-14,600	989	1133	1330	1438
42	11,800-17,600	1202	1392	1652	1713
47	15,000-22,500	1688	1907	2195	2249
52-1/2	18,600-28,000	2143	2405	2761	2820
59-1/2	24,200-36,300	3122	3497	4031	3827
67-1/2	30,300-45,500	3879	4364	5053	4800
75-5/16	37,000-55,400	5513	-	-	-

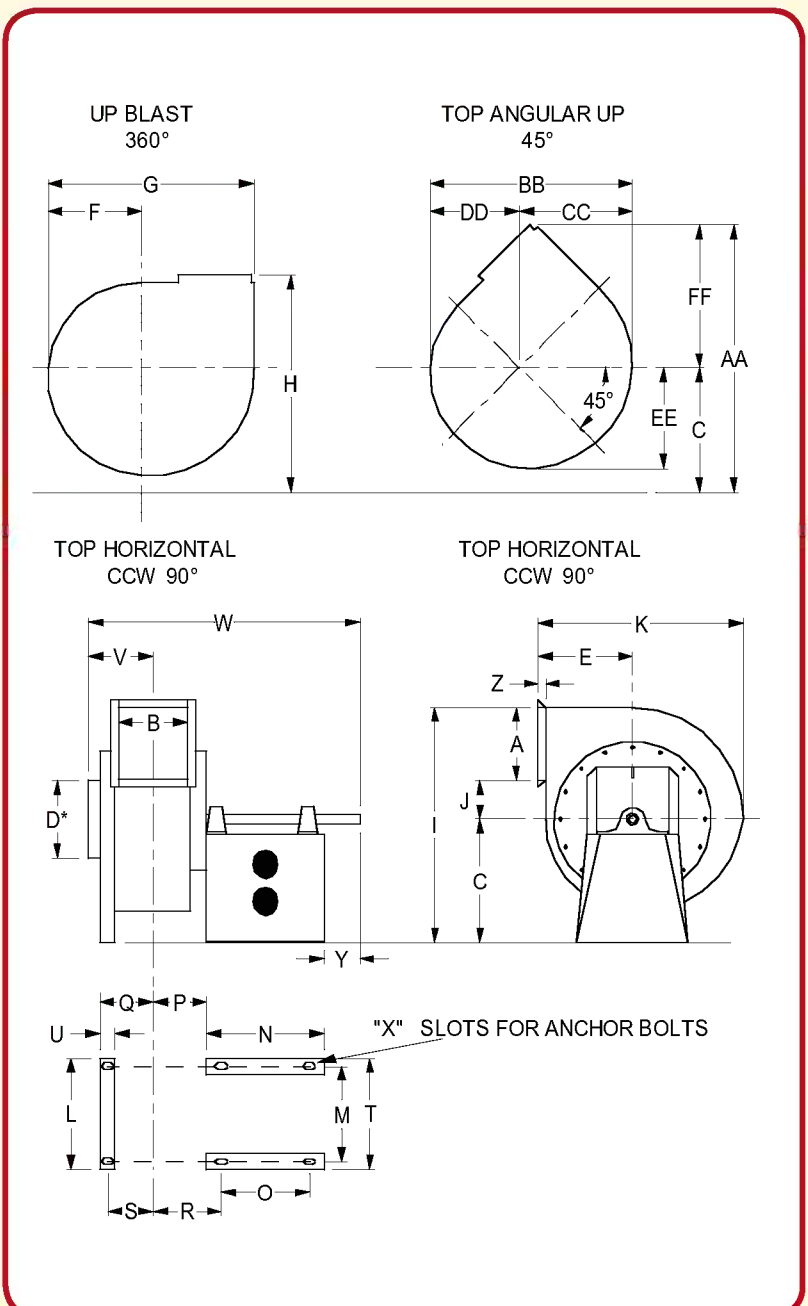

# HF6 & HF8

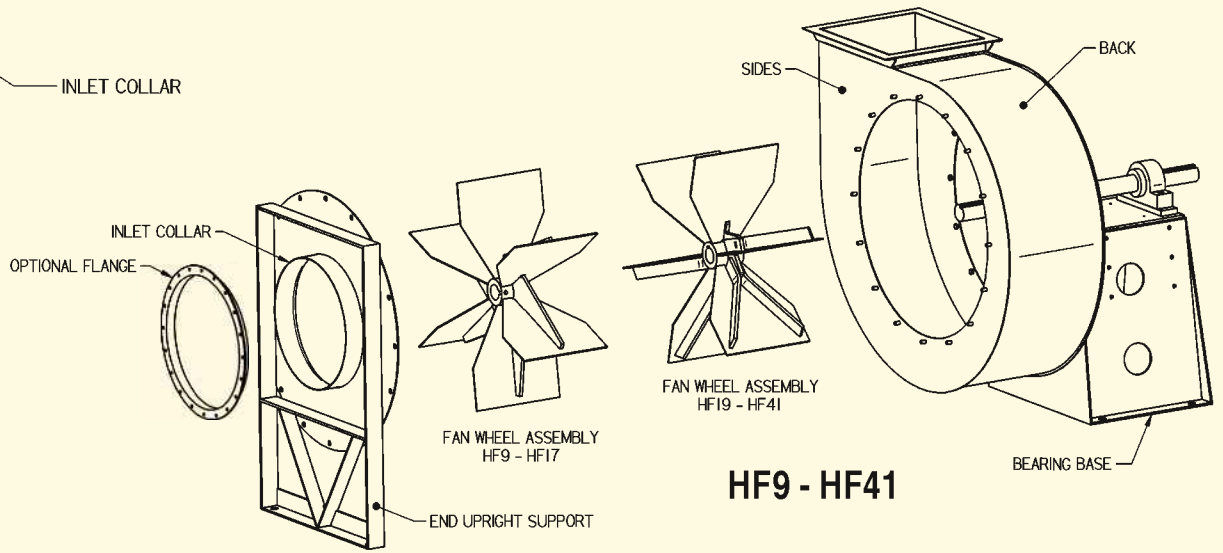
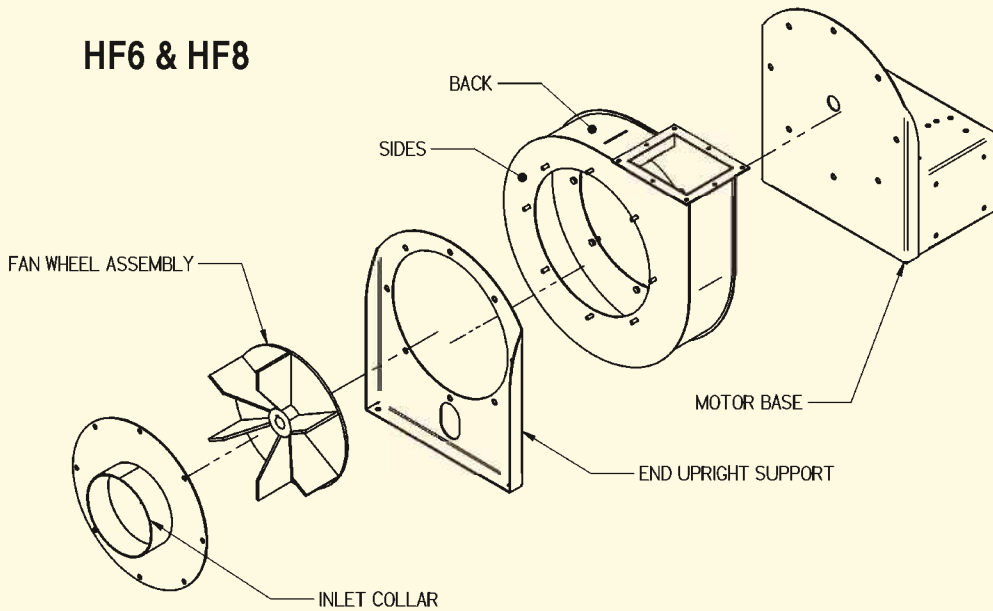

## Housing Specifications

Model	STD			HD			XHD			XHD-AR 400F		
	Back	Sides	O.A.	Back	Sides	O.A.	Back	Sides	O.A.	Back	Sides	O.A.
HF6	12 Ga	12 Ga	14 Ga	3/16 HR	12 Ga	10 Ga	5/16 HR	10 Ga	3/16 HR	5/16 AR	3/16 HR	3/16 AR
HF8	12 Ga	12 Ga	14 Ga	3/16 HR	12 Ga	10 Ga	5/16 HR	10 Ga	3/16 HR	5/16 AR	3/16 HR	3/16 AR
HF9	10 Ga	10 Ga	12 Ga	1/4 HR	10 Ga	3/16 HR	3/8 HR	3/16 HR	1/4 HR	3/8 AR	1/4 HR	1/4 AR
HF11	10 Ga	10 Ga	12 Ga	1/4 HR	10 Ga	3/16 HR	3/8 HR	3/16 HR	1/4 HR	3/8 AR	1/4 HR	1/4 AR
HF13	10 Ga	10 Ga	12 Ga	1/4 HR	10 Ga	3/16 HR	3/8 HR	3/16 HR	1/4 HR	3/8 AR	1/4 HR	1/4 AR
HF15	10 Ga	10 Ga	12 Ga	1/4 HR	10 Ga	3/16 HR	3/8 HR	3/16 HR	1/4 HR	3/8 AR	1/4 HR	1/4 AR
HF17	10 Ga	10 Ga	10 Ga	1/4 HR	10 Ga	3/16 HR	3/8 HR	3/16 HR	1/4 HR	3/8 AR	1/4 HR	1/4 AR
HF19	10 Ga	10 Ga	10 Ga	1/4 HR	10 Ga	3/16 HR	3/8 HR	3/16 HR	1/4 HR	3/8 AR	1/4 HR	1/4 AR
HF21	10 Ga	10 Ga	10 Ga	1/4 HR	10 Ga	3/16 HR	3/8 HR	3/16 HR	1/4 HR	3/8 AR	1/4 HR	1/4 AR
HF23	3/16 HR	3/16 HR	10 Ga	5/16 HR	3/16 HR	1/4 HR	7/16 HR	1/4 HR	5/16 HR	3/8 AR	5/16 HR	5/16 AR
HF26	3/16 HR	3/16 HR	3/16 HR	5/16 HR	3/16 HR	1/4 HR	7/16 HR	1/4 HR	5/16 HR	3/8 AR	5/16 HR	5/16 AR
HF29	3/16 HR	3/16 HR	3/16 HR	5/16 HR	3/16 HR	1/4 HR	7/16 HR	1/4 HR	5/16 HR	3/8 AR	5/16 HR	5/16 AR
HF33	1/4 HR	1/4 HR	3/16 HR	3/8 HR	1/4 HR	1/4 HR	1/2 HR	5/16 HR	5/16 HR	3/8 AR	5/16 HR	5/16 AR
HF37	1/4 HR	1/4 HR	3/16 HR	3/8 HR	1/4 HR	1/4 HR	1/2 HR	5/16 HR	5/16 HR	3/8 AR	5/16 HR	5/16 AR
HF41	5/16 HR	5/16 HR	1/4 HR	-	-	-	-	-	-	-	-	-

NOTES: O.A. = Outlet Adapter Rectangle to Round



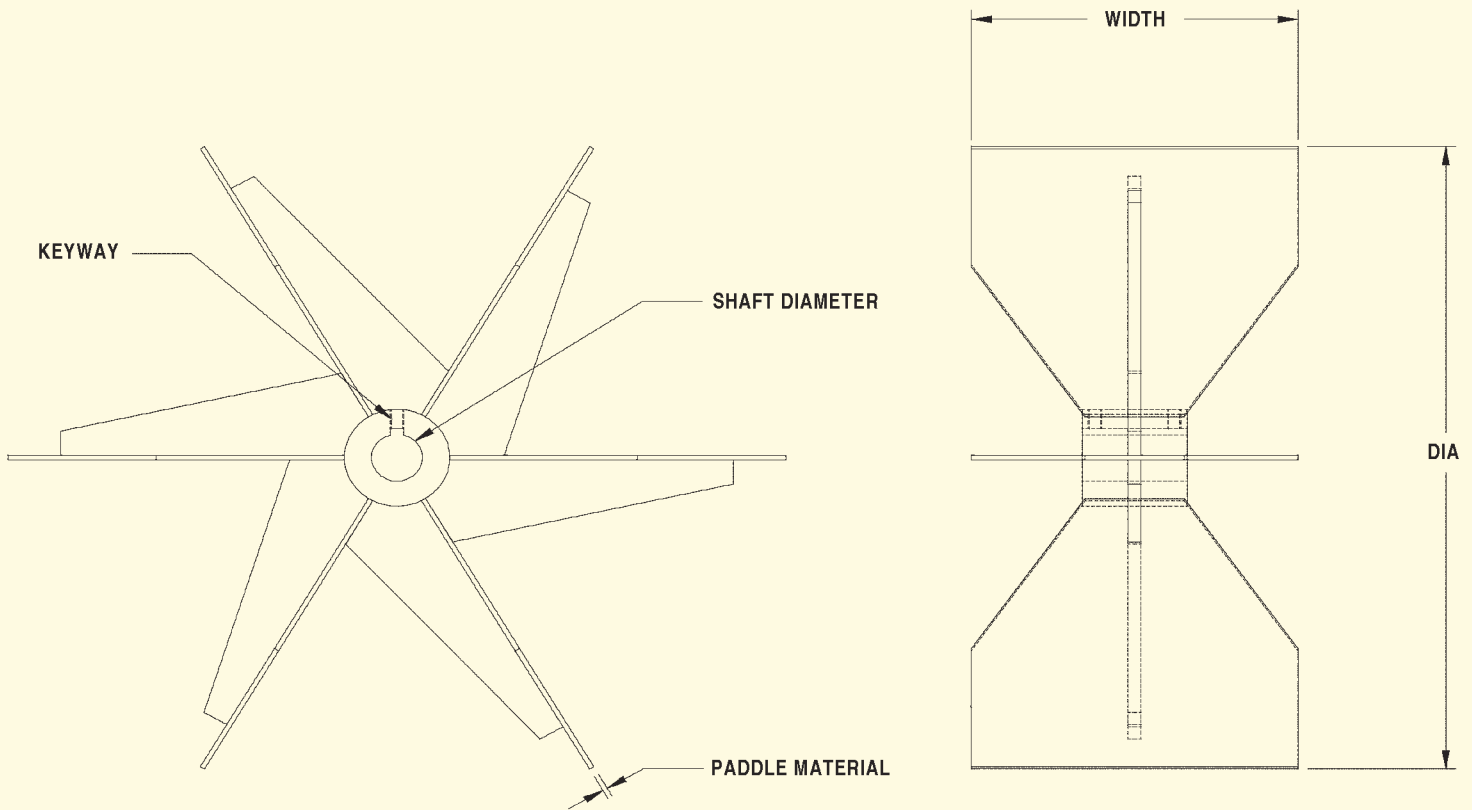

**Fan Wheel Assembly**  
Format shown for models # HF9 thru HF17

Wheel Specifications							Shaft Specifications			
Model	Dimensions		Paddle Material				Diameter		Shaft Length	Keyway in Shaft
	Dia.	Width	STD	HD	XHD	XHD-AR 400F	STD & HD	XHD		
HF6	12-1/2	3-1/4	1/4 HR	-	-	-	1-1/8	-	17	1/4 x 1/8 x 2
HF8	13-3/4	4	1/4 HR	-	3/8 HR	-	1-1/8	1-3/8	17	1/4 x 1/8 x 2
HF9	15-1/2	6-3/4	3/16 HR	5/16 HR	7/16 HR	1/2 AR	1-7/16	1-11/16	28-1/2	3/8 x 3/16 x 3-1/2
HF11	19	8	3/16 HR	5/16 HR	7/16 HR	1/2 AR	1-11/16	1-15/16	32	3/8 x 3/16 x 3-1/2
HF13	22-1/2	9-1/2	3/16 HR	5/16 HR	7/16 HR	1/2 AR	1-11/16	1-15/16	34	3/8 x 3/16 x 3-1/2
HF15	26	10-7/8	3/16 HR	5/16 HR	7/16 HR	1/2 AR	1-15/16	2-3/16	37	1/2 x 1/4 x 4-1/2
HF17	29-1/2	12-3/8	3/16 HR	5/16 HR	7/16 HR	1/2 AR	1-15/16	2-3/16	38-1/4	1/2 x 1/4 x 4-1/2
HF19	32-1/2	13-11/16	3/16 HR	5/16 HR	7/16 HR	1/2 AR	2-3/16	2-7/16	40-1/2	1/2 x 1/4 x 5-1/2
HF21	36-1/4	15-5/16	3/16 HR	5/16 HR	7/16 HR	1/2 AR	2-7/16	2-11/16	43-1/2	5/8 x 5/16 x 5-1/2
HF23	39-3/4	16-3/4	3/16 HR	5/16 HR	7/16 HR	1/2 AR	2-7/16	2-11/16	45	5/8 x 5/16 x 5-1/2
HF26	45-1/8	18-7/8	1/4 HR	3/8 HR	1/2 HR	1/2 AR	2-11/16	2-15/16	49-1/2	5/8 x 5/16 x 6-1/2
HF29	50-1/2	21-1/8	1/4 HR	3/8 HR	1/2 HR	1/2 AR	3-3/16	3-7/16	57-1/2	3/4 x 3/8 x 6-1/2
HF33	57-1/2	24	5/16 HR	7/16 HR	9/16 HR	1/2 AR	3-7/16	3-15/16	64-1/4	7/8 x 7/16 x 8
HF37	64-3/8	27-1/8	5/16 HR	7/16 HR	9/16 HR	1/2 AR	3-15/16	4-7/16	72	1 x 1/2 x 9-3/4
HF41	71-1/4	30	5/16 HR	-	-	-	4-7/16	-	79	1 x 1/2 x 9-3/4

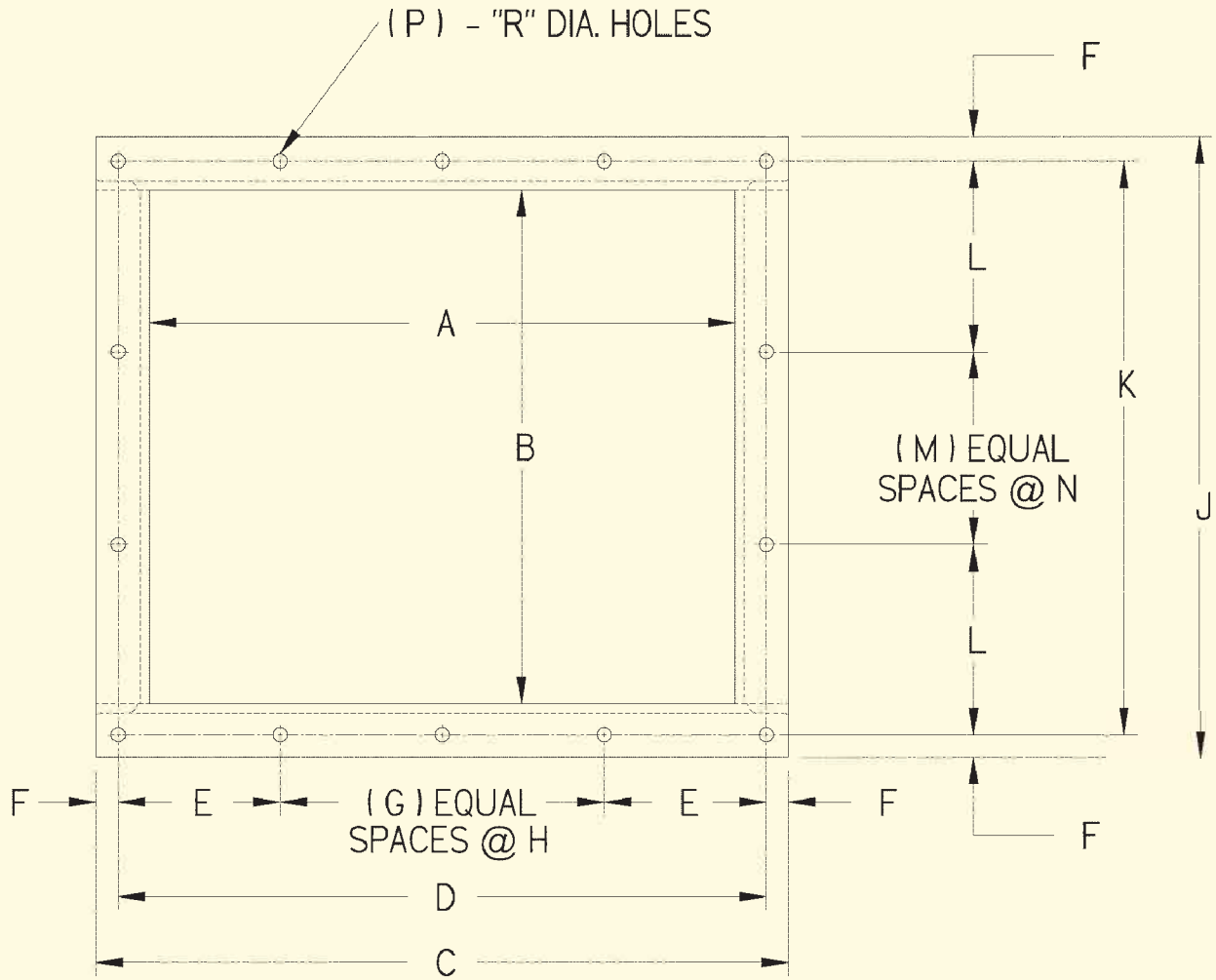

### Outlet Flange Dimensions

Model	A	B	C	D	E	F	G	H	J	K	L	M	N	P	R	Angle Flange Material
HF6	5-1/2	4-1/4	7-1/2	6-5/8	3-5/16	7/16	N/A	N/A	6-1/4	5-3/8	2-11/16	N/A	N/A	8	11/32	1 x 3/16
HF8	7-1/4	5-3/4	9-1/4	8-1/4	2-3/4	1/2	1	2-3/4	7-3/4	6-3/4	3-3/8	N/A	N/A	14	11/32	1 x 3/16
HF9	9-1/16	8	12-1/16	10-3/4	5-3/8	5/8	N/A	N/A	11	9-3/4	4-7/8	N/A	N/A	8	13/32	1-1/2 x 1-1/2 x 3/16
HF11	10-3/4	9-7/16	13-3/4	12-1/2	4	5/8	1	4-1/2	12-7/16	11-3/16	5-19/32	N/A	N/A	10	13/32	1-1/2 x 1-1/2 x 3/16
HF13	12-7/8	11-1/8	15-7/8	14-5/8	4-25/32	5/8	1	5-1/16	14-1/8	12-7/8	6-7/16	N/A	N/A	10	13/32	1-1/2 x 1-1/2 x 3/16
HF15	14-3/4	12-3/4	17-3/4	16-1/2	4-1/8	5/8	2	4-1/8	15-3/4	14-1/2	3-5/8	2	3-5/8	16	13/32	1-1/2 x 1-1/2 x 3/16
HF17	16-1/2	14-1/2	19-1/2	18.25	4-9/16	5/8	2	4-9/16	17-1/2	16-1/4	5-13/32	1	5-7/16	14	13/32	1-1/2 x 1-1/2 x 1/4
HF19	18-3/8	16	21-3/8	20-1/16	5-1/32	21/32	2	5	19	17-11/16	5-29/32	1	5-7/8	14	13/32	1-1/2 x 1-1/2 x 1/4
HF21	20-3/8	17-11/16	24-3/8	22-5/8	5-21/32	7/8	2	5-21/32	21-11/16	19-15/16	6-21/32	1	6-21/32	14	13/32	2 x 2 x 3/16
HF23	22-7/16	19-9/16	26-7/16	24-11/16	4-15/16	7/8	3	4-15/16	23-9/16	21-3/16	5-29/64	2	5-29/64	18	13/32	2 x 2 x 3/16
HF26	25-5/16	22	29-5/16	27-9/16	4-21/32	7/8	4	4-9/16	26	24-1/4	4-13/16	3	4-7/8	22	13/32	2 x 2 x 1/4
HF29	28-1/8	24-9/16	32-1/8	30-3/8	5-1/16	7/8	4	5-1/16	28-9/16	26-13/16	5-11/16	3	5-3/8	22	13/32	2 x 2 x 1/4
HF33	31-15/16	28-3/16	35-15/16	34-3/16	5-3/32	7/8	4	6	32-3/16	30-7/16	6-7/32	3	6	22	13/32	2 x 2 x 1/4
HF37	35-15/16	31-5/16	39-15/16	38-3/16	4-1/16	7/8	5	6	35-5/16	33-9/16	4-25/32	4	6	26	13/32	2 x 2 x 1/4
HF41	39-11/16	34-11/16	43-11/16	41-15/16	5-31/32	7/8	5	6	38-11/16	36-15/16	3-15/32	5	6	28	13/32	2 x 2 x 1/4



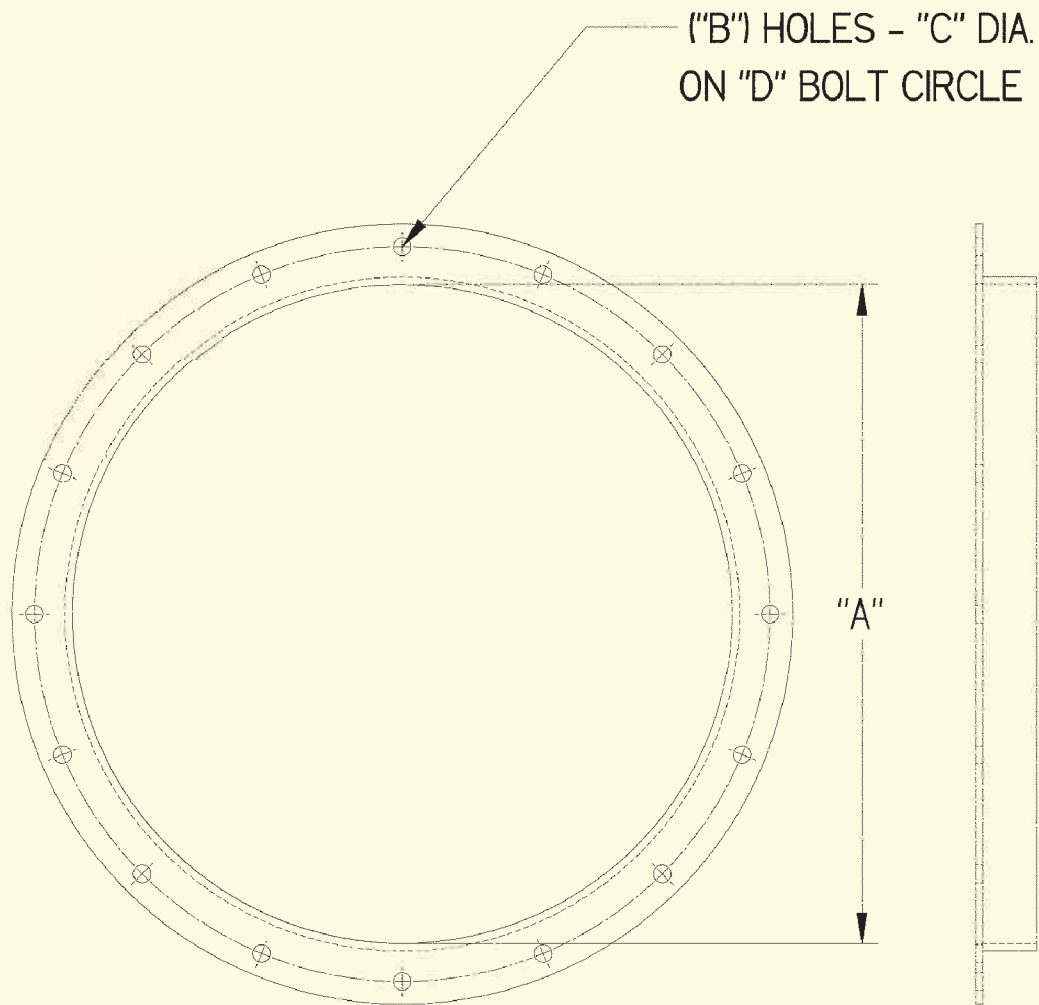

Inlet Flange Dimensions											
Standard, HD, XHD (*= standard straight collar, no flange)						XHD-AR					
Model	A	B	C	D	Flange Material	Model	A	B	C	D	Flange Material
*HF6	6-1/8	6	5/16	7-1/2	1-1/4 x 1-1/4 x 1/8	HF6	6-1/8	6	5/16	7-1/2	1-1/4 x 1-1/4 x 1/8
*HF8	8-1/8	8	3/8	9-1/2	1-1/4 x 1-1/4 x 1/8	HF8	8-1/8	8	3/8	9-1/2	1-1/4 x 1-1/4 x 1/8
*HF9	9-1/8	8	3/8	10-1/2	1-1/4 x 1-1/4 x 1/8	HF9	9-1/8	8	3/8	10-1/2	1-1/4 x 1-1/4 x 1/8
*HF11	11-1/8	8	3/8	12-1/2	1-1/4 x 1-1/4 x 1/8	HF11	11-1/8	8	3/8	12-1/2	1-1/4 x 1-1/4 x 1/8
*HF13	13	10	3/8	14-7/16	1-1/4 x 1-1/4 x 1/8	HF13	13-3/16	12	7/16	14-13/16	1-1/2 x 1-1/2 x 1/8
*HF15	15	12	3/8	16-3/8	1-1/4 x 1-1/4 x 1/8	HF15	15-3/16	16	7/16	16-13/16	1-1/2 x 1-1/2 x 1/8
*HF17	17	12	3/8	18-7/16	1-1/4 x 1-1/4 x 1/8	HF17	17-1/4	16	7/16	19-1/8	1-1/2 x 1-1/2 x 3/16
HF19	19	12	3/8	20-3/8	1-1/4 x 1-1/4 x 1/8	HF19	19-1/4	16	7/16	21-1/8	1-1/2 x 1-1/2 x 3/16
HF21	21	18	3/8	22-1/2	1-1/4 x 1-1/4 x 1/8	HF21	21-1/4	20	7/16	23-1/8	1-1/2 x 1-1/2 x 3/16
HF23	23	18	3/8	24-1/2	1-1/4 x 1-1/4 x 1/8	HF23	23-1/4	20	7/16	25-1/8	1-1/2 x 1-1/2 x 3/16
HF26	26	22	3/8	27-7/16	1-1/4 x 1-1/4 x 1/8	HF26	26-1/4	24	9/16	28-1/2	2 x 2 x 3/16
HF29	29	20	3/8	30-7/16	1-1/2 x 1-1/2 x 1/8	HF29	29-1/4	24	9/16	31-1/2	2 x 2 x 3/16
HF33	33	22	3/8	34-7/16	1-1/2 x 1-1/2 x 1/8	HF33	33-1/4	32	9/16	35-1/2	2 x 2 x 3/16
HF37	37	24	3/8	38-1/2	1-1/2 x 1-1/2 x 1/8	HF37	37-1/4	36	9/16	39-1/2	2 x 2 x 3/16
HF41	41	24	3/8	43-7/16	2 x 2 x 1/8	HF41	41-1/4	40	9/16	43-1/2	2 x 2 x 3/16

# HBCF Clean Air Fans



The HBCF Negative System Fans are designed with a backward curve, centrifugal blade for clean air applications. With inlet sizes of 20" through 63" and recommended CFM ratings of 5,200 to 54,000, HBCF Fans provide a wide range of options to fit your particular needs.

Model Number	Inlet size	Wheel Dia.	Brake hp	CFM @ 11" SP
HBCF20	20"	18"	19	6,450
HBCF26	26"	24"	23.5	9,100
HBCF32	32"	30"	38	14,090
HBCF38	38"	36"	47	18,780
HBCF42	42"	40"	57	23,500
HBCF47	47"	44"	72	26,400
HBCF52	52"	49"	93	34,000
HBCF57	57"	54"	95	36,500
HBCF63	63"	60"	119	41,000



# Honeyville Cyclones



- Twenty one standard models, five high efficiency, and ten high efficiency/high volume to cover a vast variety of cyclonic needs.
- Continuous welded carbon steel, for longer wear.
- Top outlet vent cap available in either adjustable weather cap for venting into atmosphere or manifold to return air through a filter back into building.
- Safety ring mounted on roof edge for attachment of the installers P.P.E. (personal protection equipment) while they are installing the manifold or vent cap.
- Finish coated exterior surface consists of base primer coat and industrial enamel finish.
- 14" diameter cone access/inspection panel with bolt on construction. Laminated panel is flush with the inside surface.

- **MATERIAL:** All welded HR steel with three gauge thickness classifications available: Standard Duty, Heavy Duty, and Extra Heavy Duty, optional Materials: AR Steel, G90 Galvanized Steel, and Stainless Steel



Larger diameter cyclones can be split vertically as well as horizontally for shipping purposes.



In this application, the cyclone is being used as a silo receiver cone at a sawmill.

# Round Welded Baghouse Filters



## Honeyville Medium Pressure Cleaning (MPC) Filter

- **Capacities:** Ranges from 9,600 to 61,000 CFM (calculated at 8:1 air to cloth ratio)
- **Bag Cleaning:** Medium pressure back flush cleaning of bags
- **Cone:** 70° standard cone section with bolt-on inspection cover
- **Inlet:** Low pressure 110° involute inlet section with inner cone baffle and vortex breakers. Optional high entry inlet
- **Bags:** 4.6" dia. 16 oz. polyester bags with mirror finish
- **Cages:** 4.5" dia. galvanized wire cages
- **Bag Removal:** No-tool top bag and cage removal
- **Construction:** Welded and bolted construction using hot rolled carbon steel
- **X-Venting:** Explosion relief panels
- **Finish:** The interior and exterior are prime coated followed by a silicone alkyd industrial enamel paint on the exterior



## Honeyville Pulse-Jet (EFR) Filter

- **Capacities:** Ranges from 1,050 to 10,000 CFM (calculated at 8:1 air to cloth ratio)
- **Cone:** 67° standard cone section with bolt-on inspection cover
- **Inlet:** Low pressure 110° involute inlet section with inner cone baffle and vortex breakers. Optional high entry inlet
- **Baffle:** Inner cone baffle with vortex breakers
- **Bags:** 4.6" dia. 16 oz. polyester bags with mirror finish
- **Cages:** 4.5" dia. galvanized wire cages
- **X-Venting:** Explosion relief panels
- **Bag Removal:** No-tool top bag and cage removal



# Galvanized Sectional Baghouse Filters

## Honeyville Pulse-Jet (EFM) Filter

- **Capacities:** Ranges from 3,100 to 31,000 CFM (calculated at 8:1 air to cloth ratio)
- **Construction:** All-bolted construction using G90 galvanized steel formed panels
- **Baffles:** Particulate deflector baffles
- **Hopper:** 60 degree 2-way sloped hopper
- **Enclosure:** Pulse Valve enclosure to protect from the elements
- **Ladder:** Service ladder and perimeter safety railing
- **Bags:** 4.6" dia. 16 oz. polyester bags with mirror finish
- **Cages:** 4.5" dia. galvanized wire cages
- **Bag Removal:** No-tool bag and cage removal



## Honeyville Shaker (SF) Filter

- **Capacities:** Ranges from 1,300 to 6,000 CFM (calculated at 6.5:1 air to cloth ratio)
- **Construction:** All galvanized, bolted steel construction for years of service, 14 and 16 Ga. panels, 12 Ga. cell plate
- **Assembly Arrangements:** Open Bag Area Units if installed indoors or Totally Enclosed Units for outdoor or indoor installations
- **Bag Shaker Options:** Manual Shaker or Motorized Shaker (required on totally enclosed units)
- **Bags:** 5" dia. 10.5 oz polyester seamless knit bags
- **Hopper:** Low profile hopper, sloped hopper w/ steel barrels, or sloped hopper w/ plastic collection bags
- **Return Air:** Optional return air manifold for outdoor installations



# HAL Series Rotary Airlocks

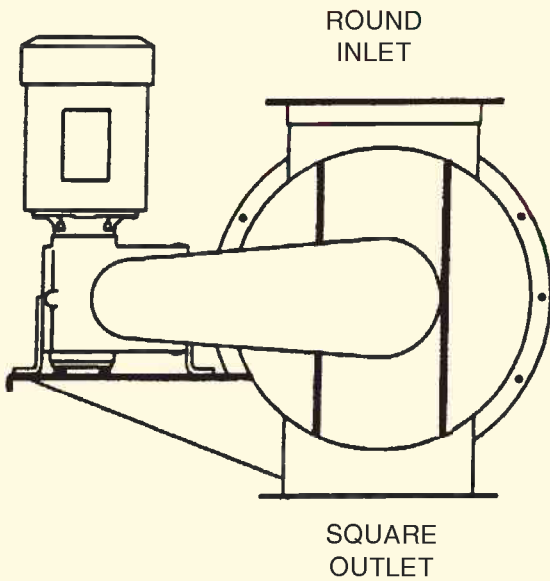

- Standard round inlet and square outlet
- 5 sizes ranging from 8"-3/4 hp to 24"-3 hp.
- Carbon steel body, end plates, and rotor assembly
- PVC flex tip wipers with optional carbon steel flex tip limiters for applications where a tighter seal is required
- Bolt-on side panel for easy access to change PVC flex tips without removing the rotor
- Drive system consists of 1800 RPM C-Face mounted motor, right angle gear reducer, and a roller chain driving the rotor



Airlock shown at left under our MPC Filter dropping into a blow through adapter in a closed loop relay system.



# Pipe, Fittings, and other Components



- **One-piece Elbows**, 3"–15", 2.5 x CLR, 45° & 90°, 22–20 gauge galvanized steel
- **Lock-seam Pipe**, 3"–37" x 10' long, 26–18 gauge galvanized steel, flanged or crimped ends
- **Welded Gore Elbows**, 6"–72", 1.5–2.5 x CLR, 18–7 gauge painted & galvanized steel, flanged or plain ends
- **Welded Pipe**, 6"–72", 16 gauge–1/4" painted & galvanized steel, flanged or plain ends
- **Flat Back Long Sweep Elbows**, 8"–22", 4'– 5' CLR, 45° & 90°, rigid or removable backs, flanged ends
- **Wye Adapters**, 3"–12" "A" & "Y" style,
- **45° Inlets**, 3"–20" pipe saddle type,
- **Tapered Reducers**, 2"–41", optional 45° inlets, flanged or plain ends
- **Cut-off Gates**, 2"–24", full & half type mountings
- **Flexible Hose & Tubing**, 2"–14", EPDM rubber, urethane & metal
- **Custom Designed Molder Manifolds**, 4–8 outlets, flanged or plain ends
- **Back Draft Dampers**, 6"–20" gravity type, flanged or plain ends
- **Fire Gates**, gravity drop type with fuse link, round & rectangle duct applications, flanged both ends
- **Diverter Valves**, 6"–20", 30° & 45°, flanged or plain ends
- **Air Diffuser Plenums for Return Air Lines**, adjustable turning vanes, multi directional
- **Winter-Summer By-Pass Dampers**, 16"–66", manual or actuator controlled, flanged ends
- **Access Covers**, no-tool removal or hinged & latched formats
- **Machine Hoods, Floor Sweeps & other components** to complete your installation







Honeyville Metal Inc.  
4200 North 900 West  
Topeka, IN 46571 USA

(800) 593-8377 Toll Free  
(260) 593-2266 Phone  
(260) 593-2486 Fax  
dustinfo@honeyvillemetal.com  
www.honeyvillemetal.com



HF-April 2012

